

Homework 10, 05/30/2019 Due: 06/05/2019

A4 professional format and you should document your codes, collecting at the BEGINNING of class (09:09 am)

(late submission within 24 hours: score*0.9; late submission before post of solution: score*0.8 (the solution will be posted usually within a week))

Total 90% + 20% Bonus

1. (30%) Consider a cubic Lagrange element shown below. Find the shape functions for nodes 5, 10, 14 and plot these shape functions in MATLAB.

2. (30%) Derive the shape functions for a transition element shown below using the hierarchical method.

3. (30%) Derive the shape functions for node 2 and node 12 of a cubic Serendipity type element and plot these shape functions in MATLAB

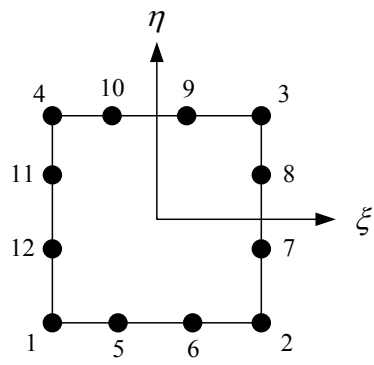

4. **(Bonus, 20%)** Consider the following Q8 element in the Cartesian coordinate. Calculate the strain-displacement matrix \mathbf{B}^e for the element at $\xi = \eta = 0$.

