

Storage

Storage

What is **storage**?

- Holds data, instructions, and information for future use
- **Storage medium** is physical material used for storage
 - Also called **secondary storage**



Storage

What is **capacity**?

- **Number of bytes (characters) a storage medium can hold**

Kilobyte (KB) 1 thousand
→

Megabyte (MB) 1 million
→

Gigabyte (GB) 1 billion
→

Terabyte (TB) 1 trillion
→

Petabyte (PB) 1 quadrillion
→

Exabyte (EB) 1 quintillion
→

Storage

How does volatility compare?

- Storage medium is **nonvolatile**—contents retained when power is off
- Memory is **volatile**—holds data and instructions temporarily

	ON	OFF
Volatile	Screen Display Display appears	Display disappears
Nonvolatile	Memory (most RAM) (chips on motherboard) Data and instructions available to user	Data and instructions erased
Nonvolatile	Storage Medium (floppy disks, Zip disks, hard disks, CDs) Contents available to user	Contents retained

Storage

What is a **storage device**?

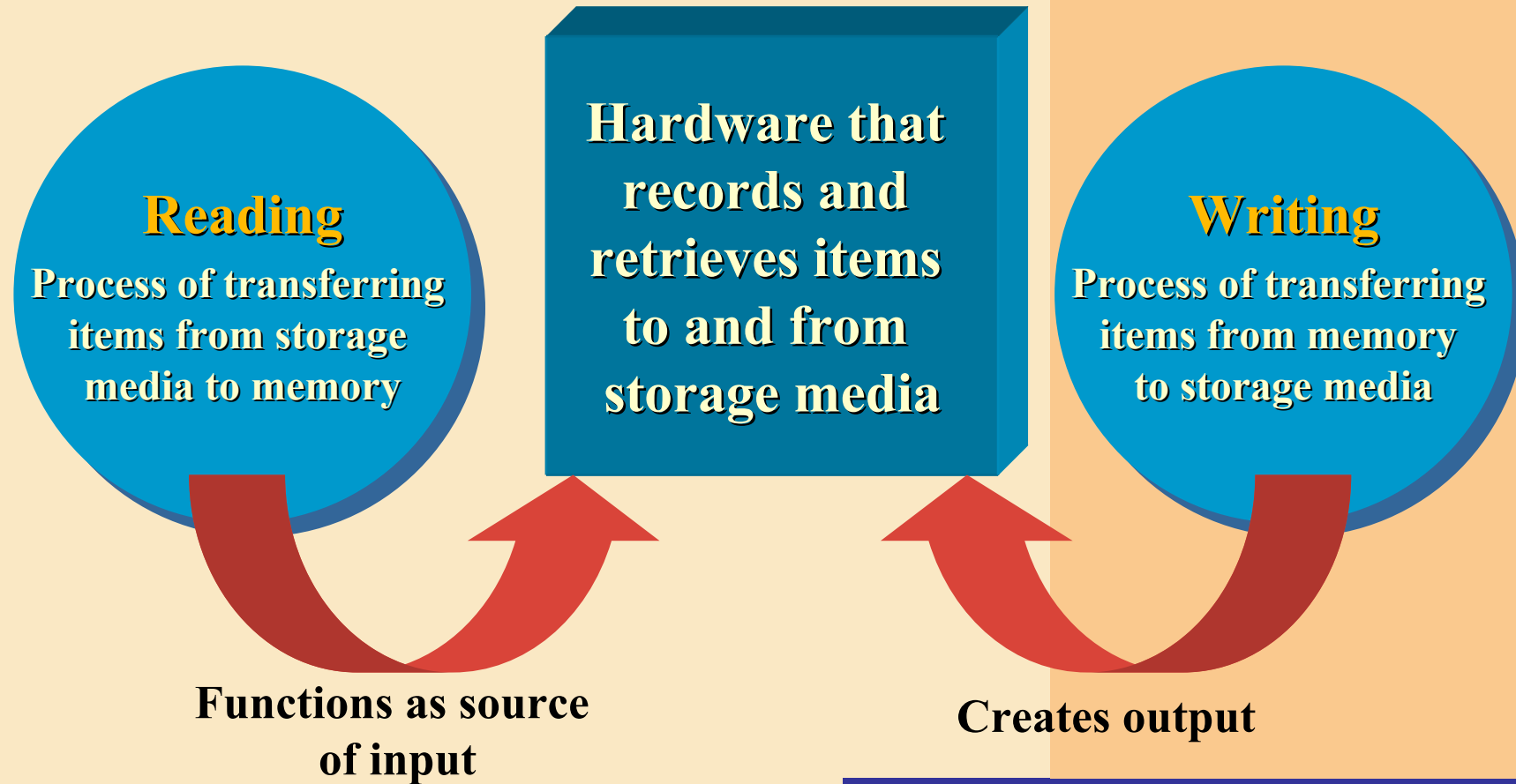

Storage

What is **access time**?

- Time it takes storage device to locate item on storage medium
- Time required to deliver item from memory to processor

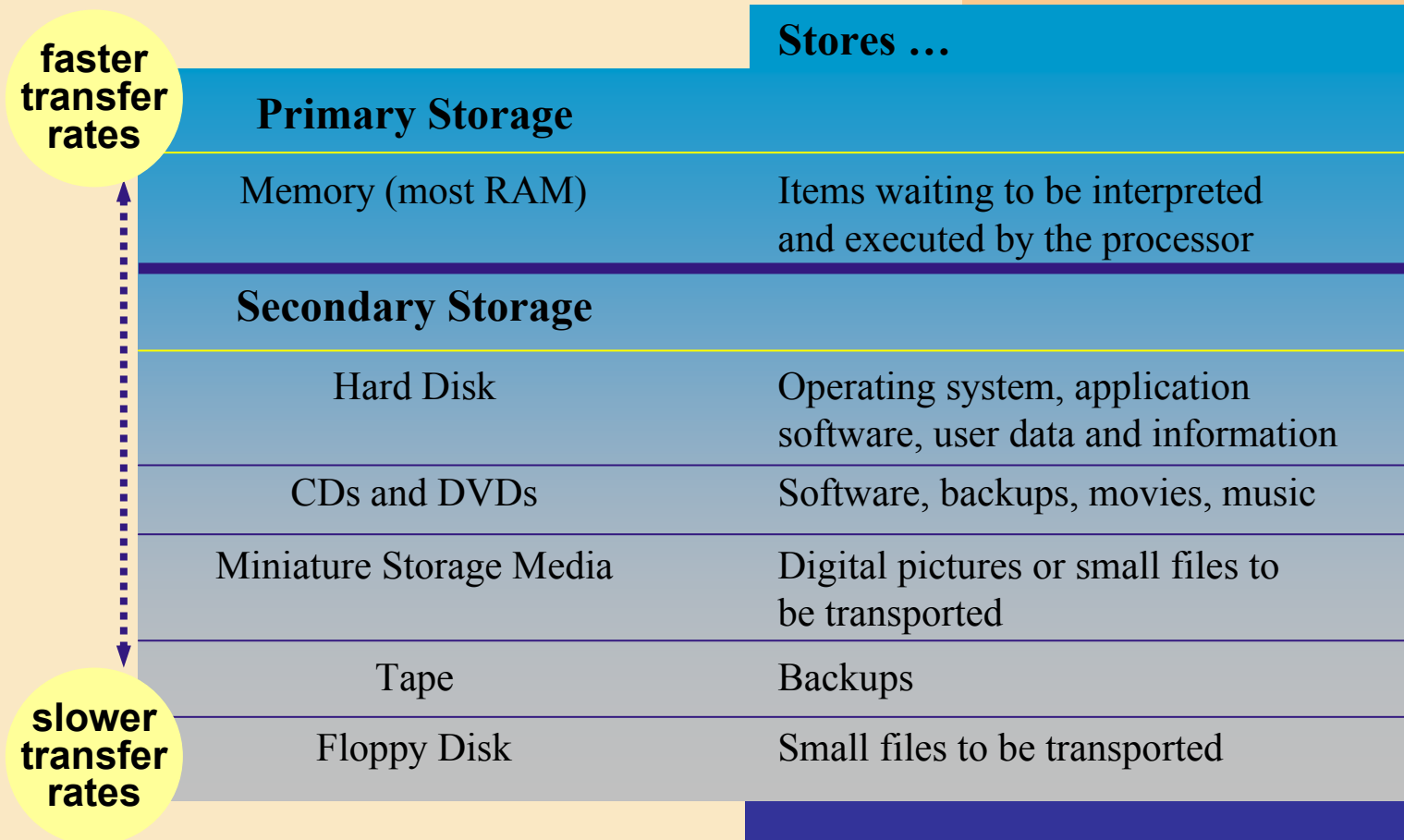

Floppy Disks

What is a **floppy disk**?

- Portable, inexpensive storage medium (also called **diskette**)



Thin, circular, flexible film enclosed in 3.5" wide plastic shell

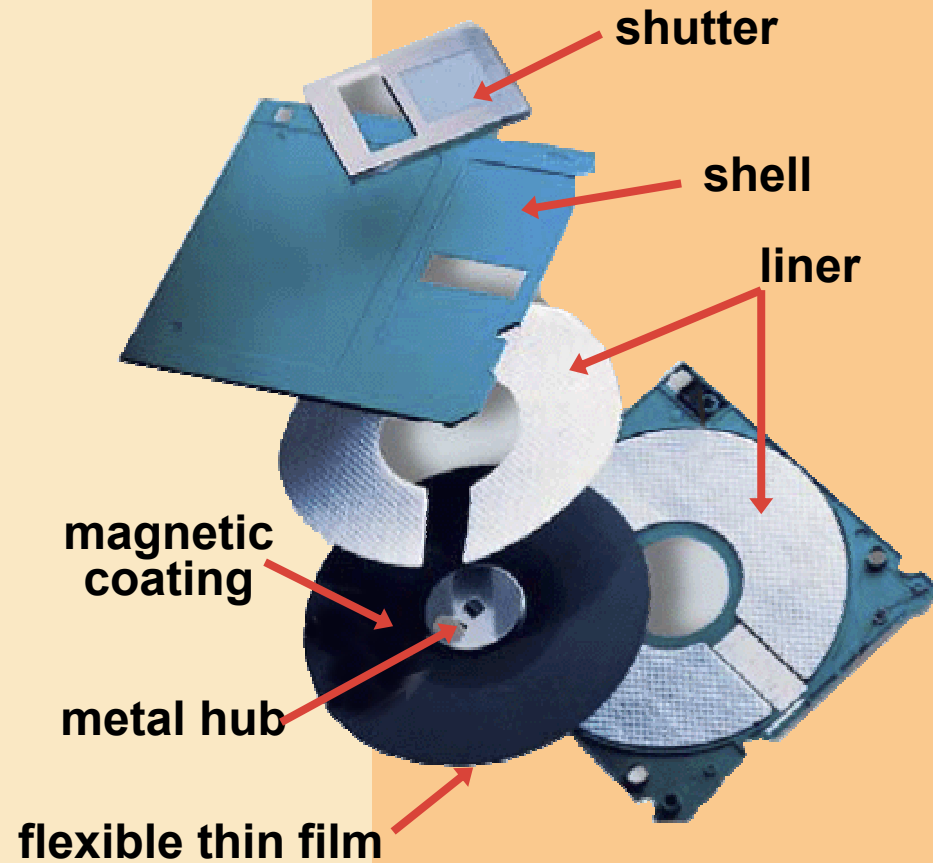

Floppy Disks

What is a **floppy disk drive**?

- **Device that reads from and writes to floppy disk**
 - One floppy drive, named drive A
 - If two floppy drives, second designated as drive B
- **Also called **secondary storage****



Floppy disk drive built into a desktop computer

External floppy disk drive attaches to a computer with a cable



Floppy Disks

How does a floppy disk drive work?

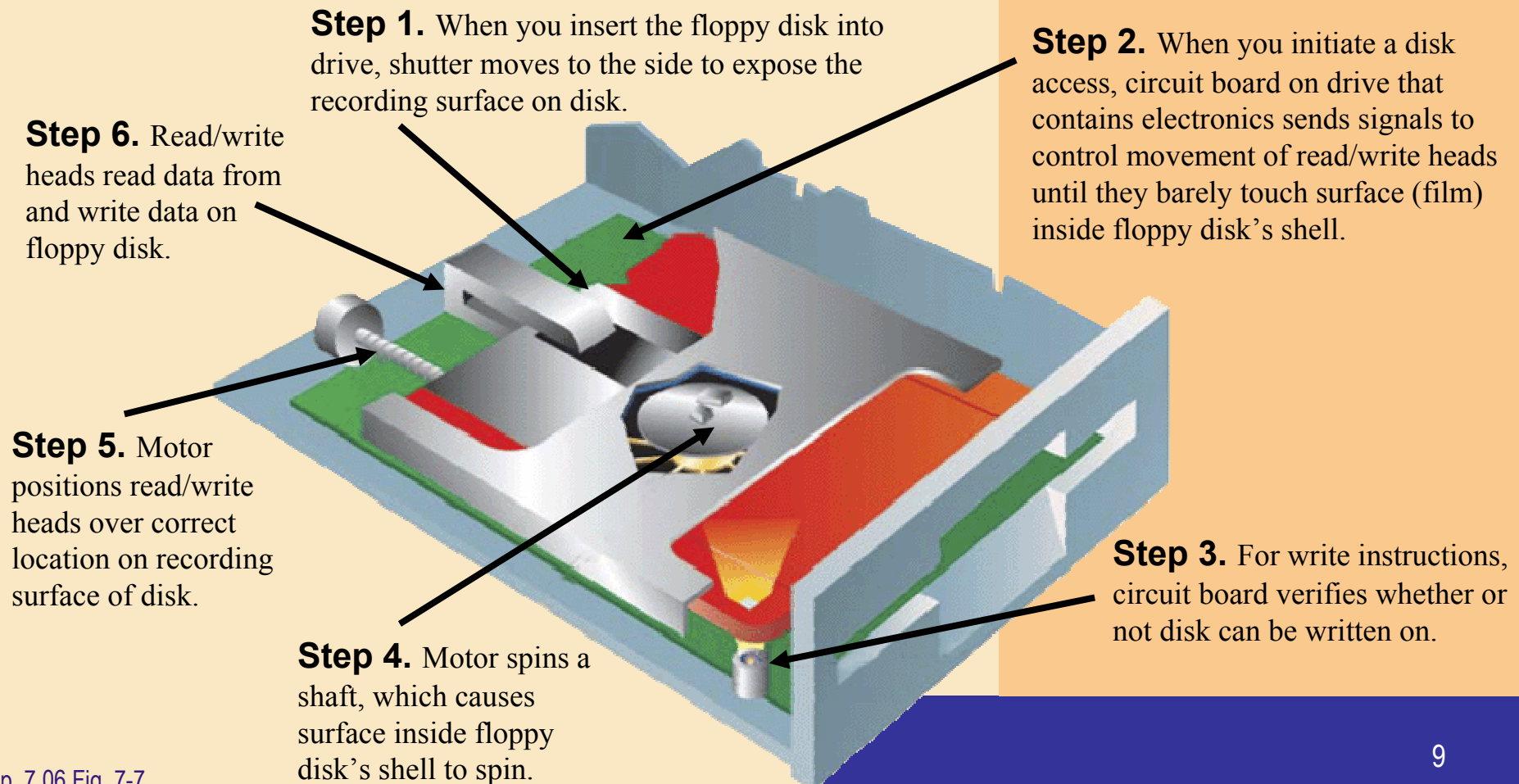

Floppy Disks

What are **tracks** and **sectors**?

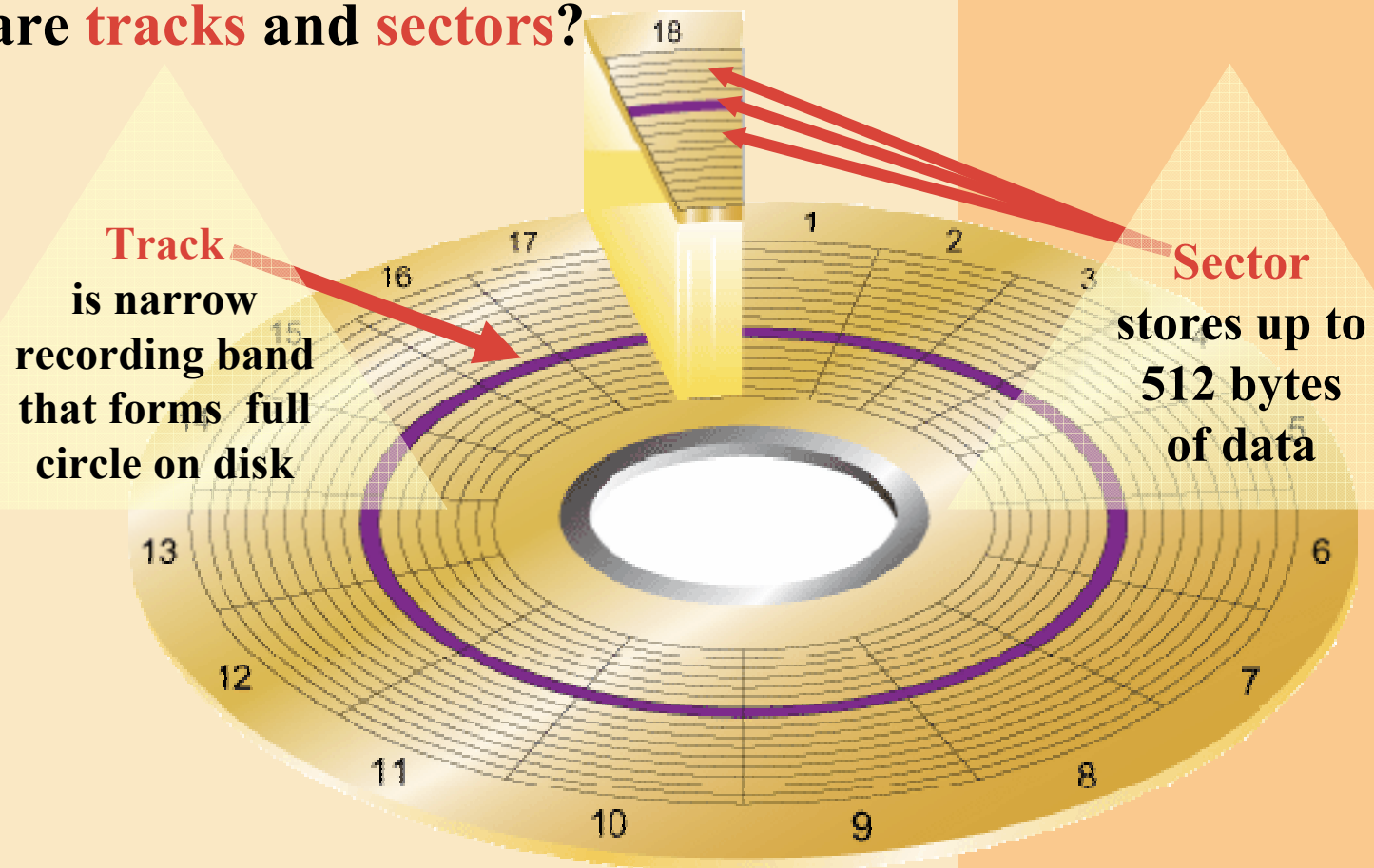

Formatting prepares disk for use and marks bad sectors as unusable

Floppy Disks

How do you compute a disk's storage capacity?

- **Multiply number of sides, number of tracks, number of sectors per track, and number of bytes per sector**
 - For high-density disk: $2 \text{ sides} \times 80 \text{ tracks} \times 18 \text{ sectors per track} \times 512 \text{ bytes per sector} = 1,474,560 \text{ bytes}$

**Characteristics of a
3.5-inch High-Density
Floppy Disk**



Capacity:	144 MB
Sides:	2
Tracks:	80
Sectors per track:	512
Sectors per disk:	2880

Floppy Disks

How do you care for a floppy?

- **Proper care helps maximize disk's life**
- **Floppy disk can last at least seven years**

Never open the shutter and touch the disk's surface

Avoid exposure to heat and cold

Avoid exposure to magnetic fields

Avoid exposure to contaminants such as dust, smoke, or salt air

Keep disks in a storage tray when not using them

Floppy Disks

What is a **write-protect notch**?

- Small opening with a cover that you slide
- Protects floppy disk from being erased accidentally



Zip[®] Disks

What is a **Zip disk**?

- **Magnetic medium that stores 100 MB or 250 MB of data**
- **Used to back up and to transfer files**
 - **Backup** is duplicate of file, program, or disk in case original is lost
- **Zip disks require a **Zip drive**—high capacity drive that reads from and writes on a Zip disk**



Hard Disks

What is a **hard disk**?

- **High-capacity storage**
- **Consists of several inflexible, circular platters that store items electronically**
- **Components enclosed in airtight, sealed case for protection**



Hard Disks

What are characteristics of a hard disk?

Sample Hard Disk Characteristics

Advertised capacity	40 GB
Platters	2
Read/write heads	4
Cylinders	16,383
Bytes per second	512
Sectors per track	63
Sectors per drive	78,165,360
Revolutions per minute	7,200
Transfer rate	100 MB per second
Access time	9 ms

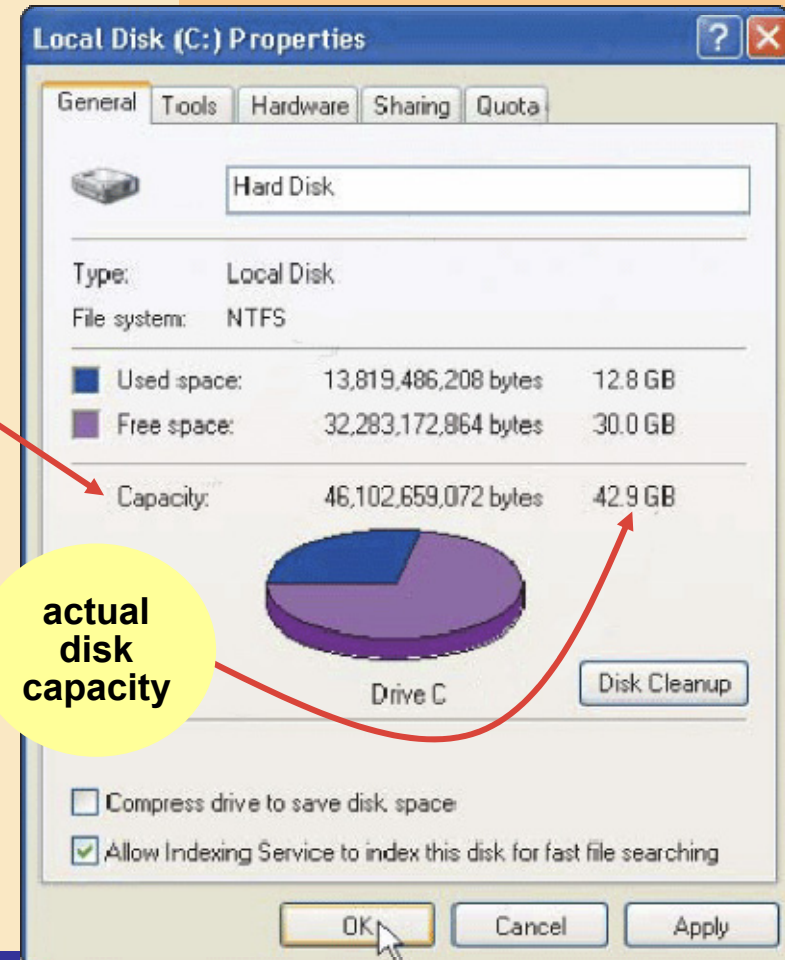

Hard Disks

How does a hard disk work?

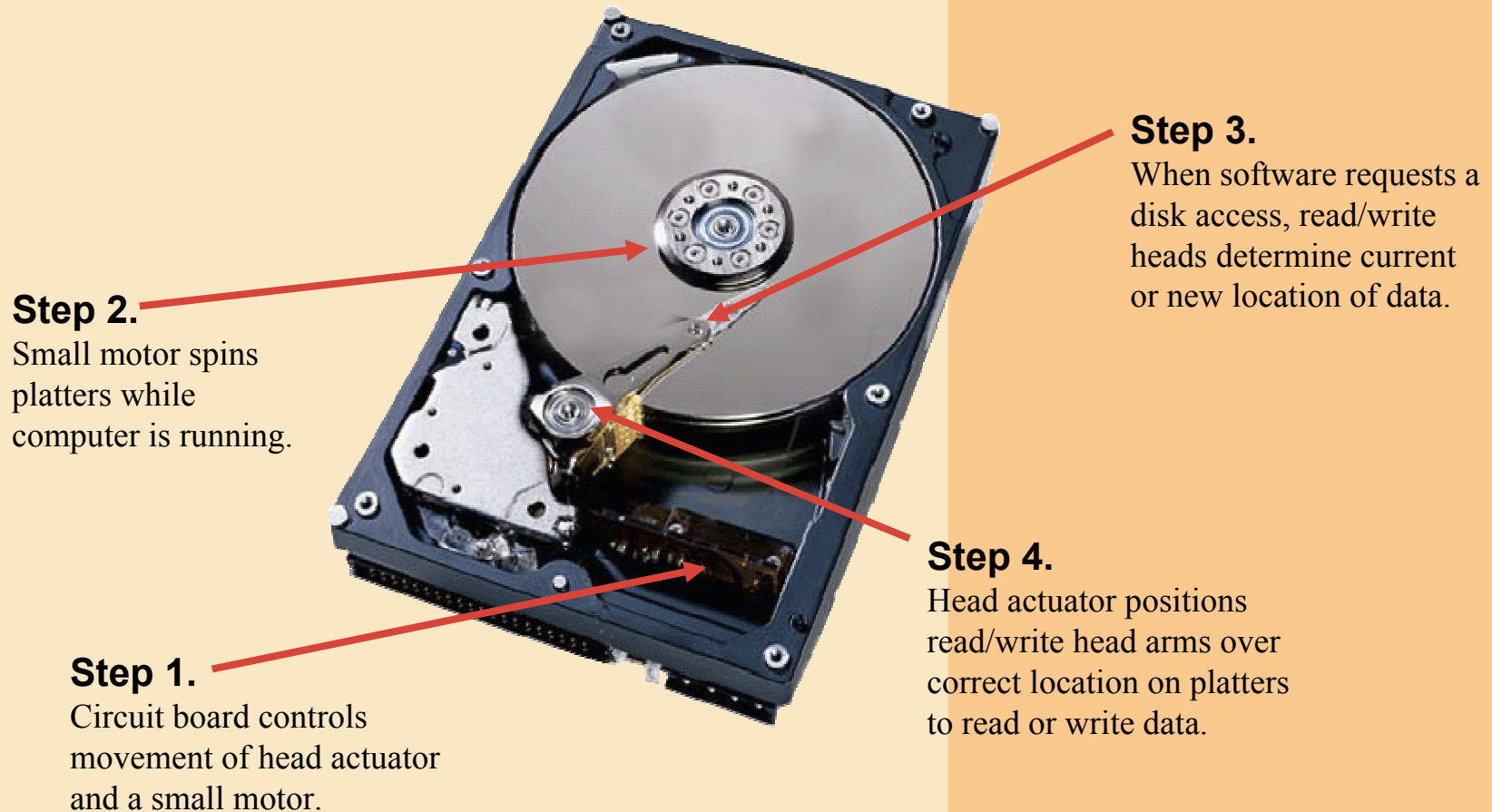

Hard Disks

What is a **cylinder**?

- Vertical section of track through all platters
- Single movement of read/write head arms accesses all platters in cylinder

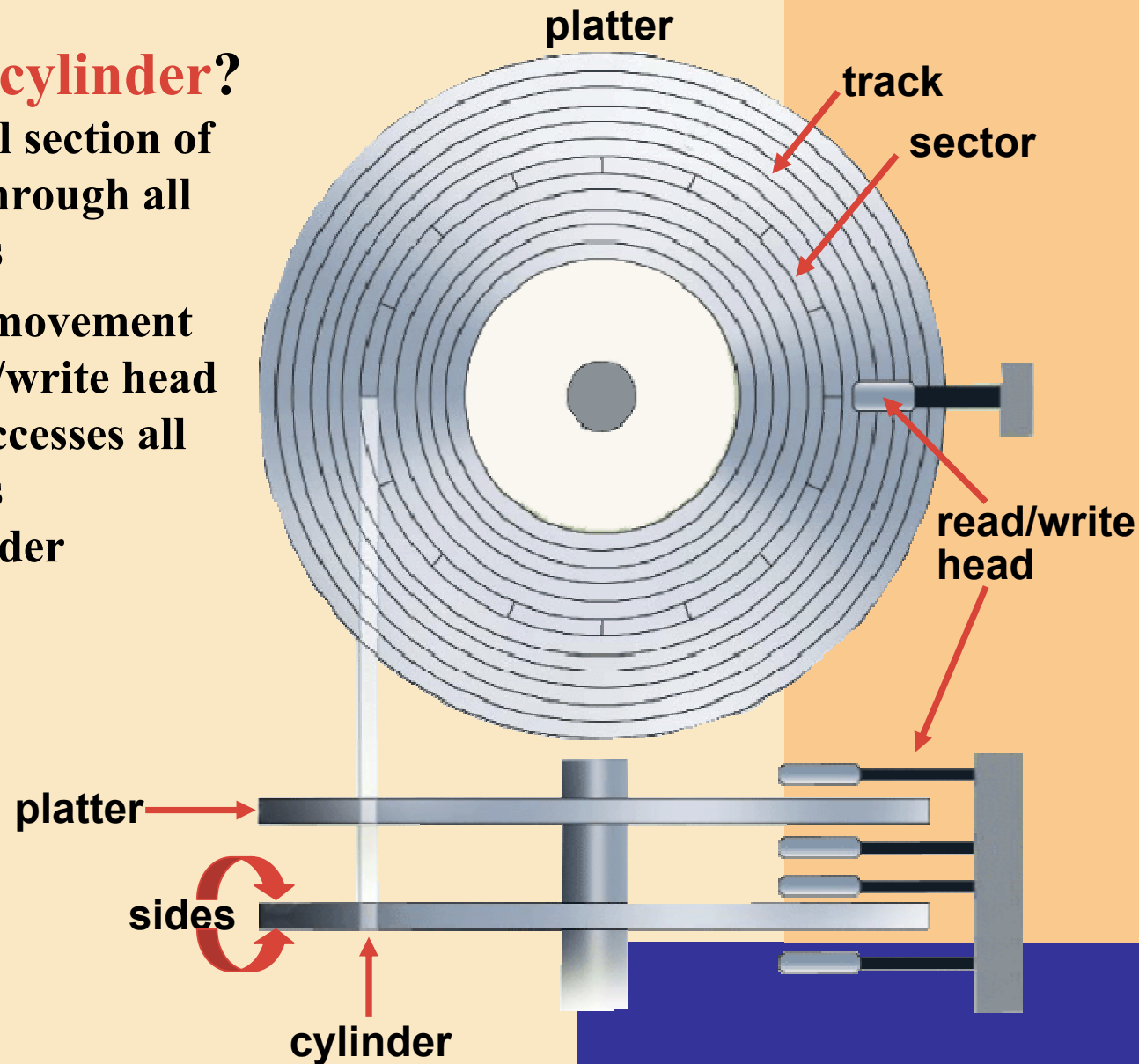

Hard Disks

What is a **head crash**?

- **Occurs when read/write head touches platter surface**
- **Spinning creates cushion of air that floats read/write head above platter**
 - Clearance between head and platter is approximately two-millionths of an inch
 - A smoke particle, dust particle, or human hair could render drive unusable

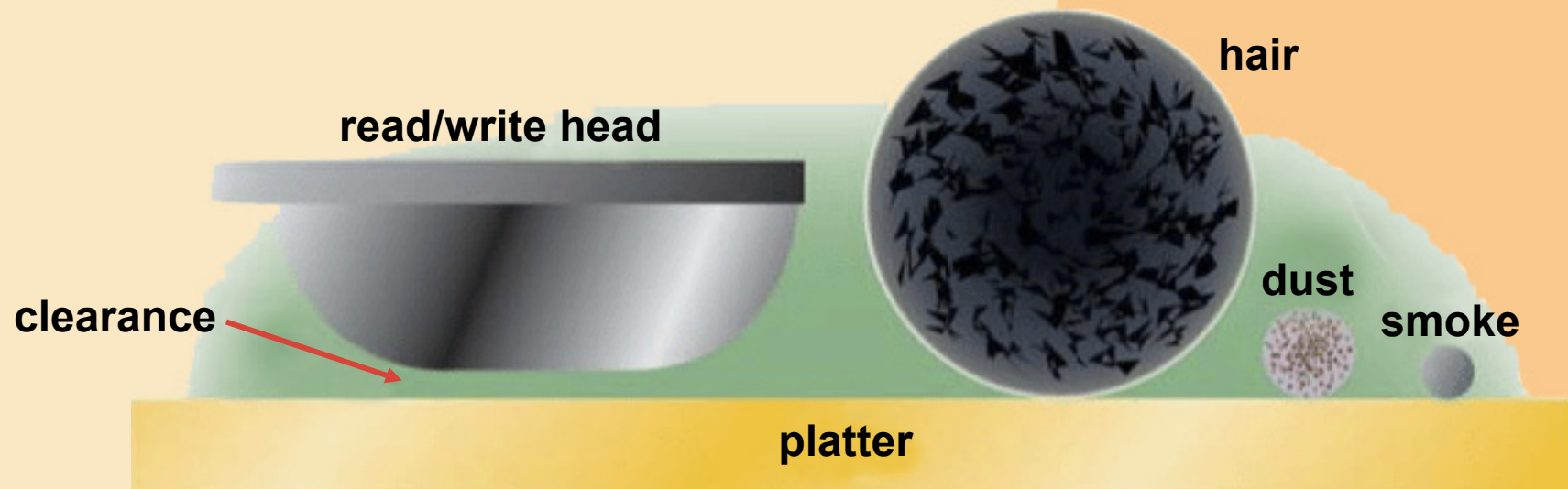

Hard Disks

What is a **disk cache**?

- Portion of memory that processor uses to store frequently accessed items

first request for data—to disk cache

second request for data—to hard disk

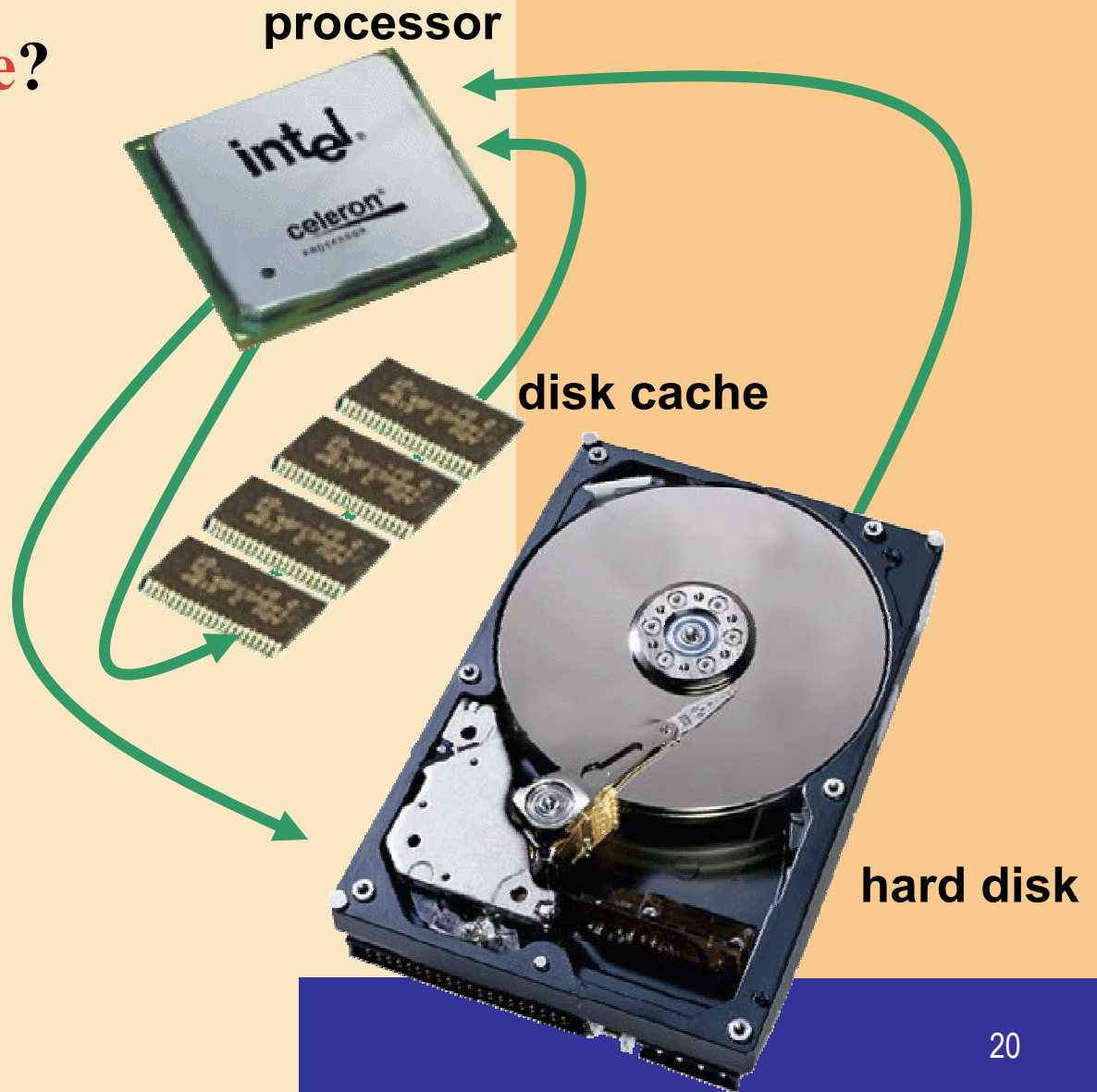

Hard Disks

What are **external hard disks** and **removable hard disks**?

- Used to back up or transfer files

External hard disk—freestanding hard disk that connects to system unit



Removable hard disk—hard disk that you insert and remove from hard disk drive



Hard Disks

What is a **disk controller**?

Chip and circuits that control transfer of items from disk

EIDE (**E**nhanced **I**ntegrated **D**rive **E**lectronics) controller supports four hard disks, provides connections for CD and DVD drives

SCSI
(**S**mall **C**omputer **S**ystem **I**nterface) controller supports up to fifteen devices including hard disks, CD and DVD drives, tape drives, printers, scanners, network cards

Hard Disks

What is an **Internet hard drive**?

- **Service on Web that provides storage for minimal monthly fee**
- **Files can be accessed from any computer with Web access**
- **Large files can be downloaded instantaneously**
- **Others can be authorized to access your data**

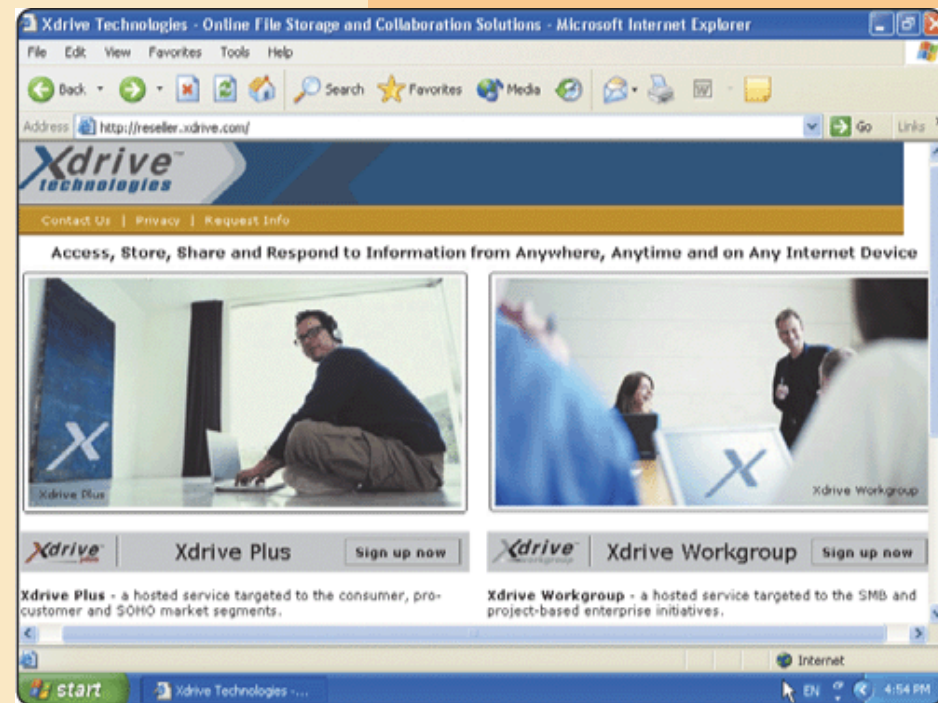

CDs and DVDs

What are **CDs** and **DVDs**?

- Flat, round, portable metal discs with protective plastic coating
- Can be read only or read/write
- Most PCs include CD or DVD drive, most play audio CDs

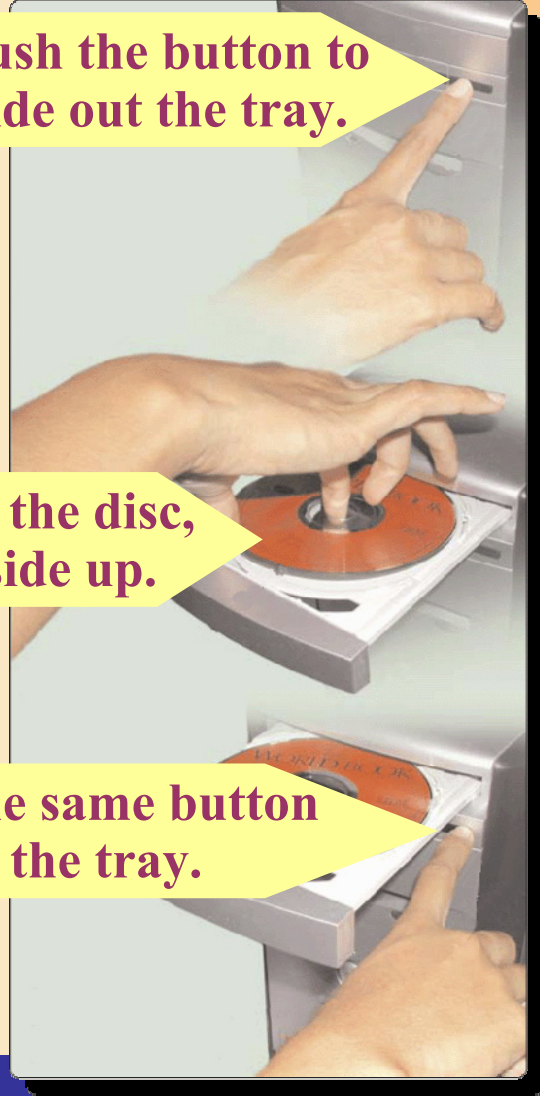

Push the button to slide out the tray.

Insert the disc, label side up.

Push the same button to close the tray.

CDs and DVDs

How does a laser read data on a CD or DVD?

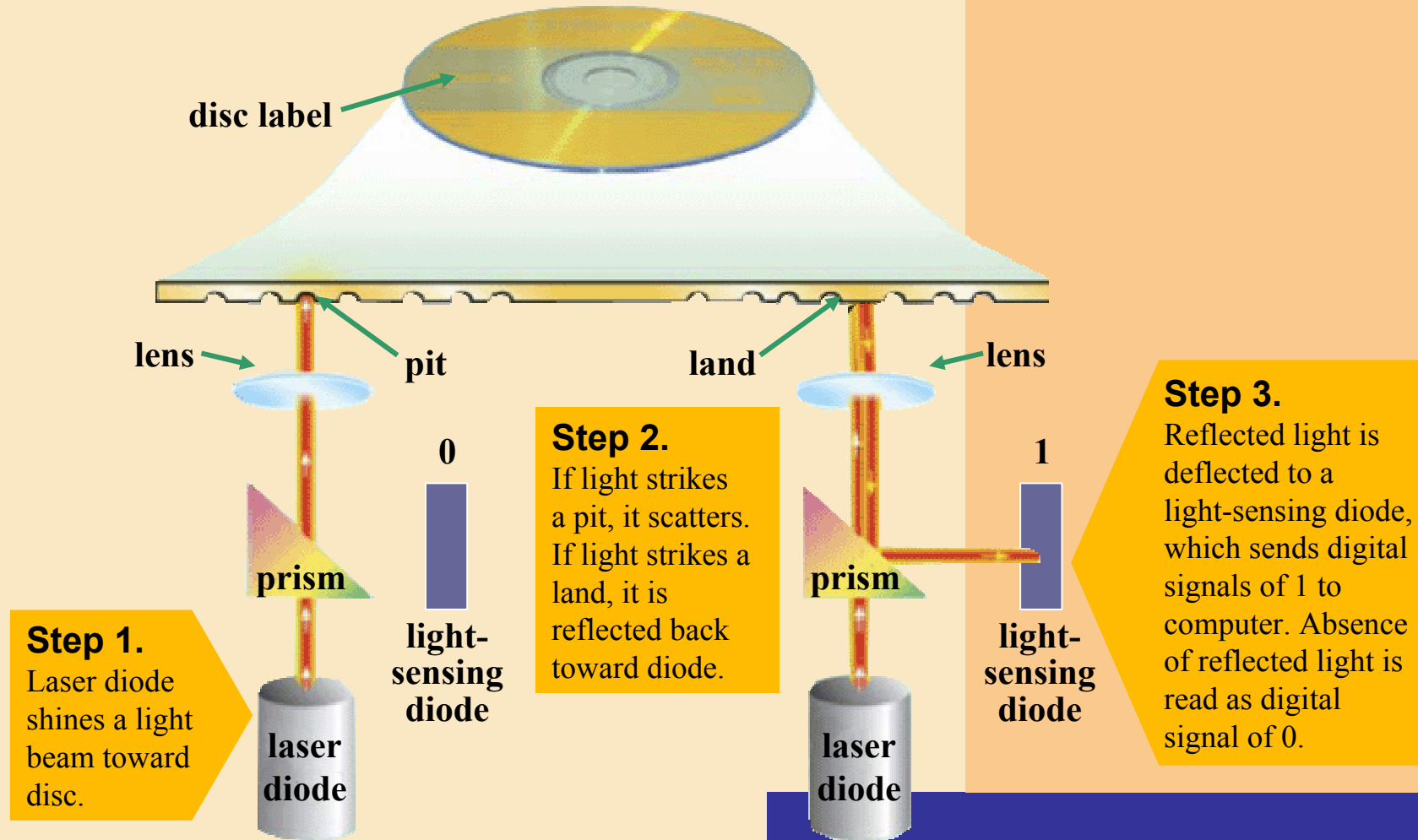

CDs and DVDs

How is data stored on a CD or DVD?

- Typically stored in **single track**
- Track divided into evenly sized **sectors** that store items

single track
spirals to edge
of disc

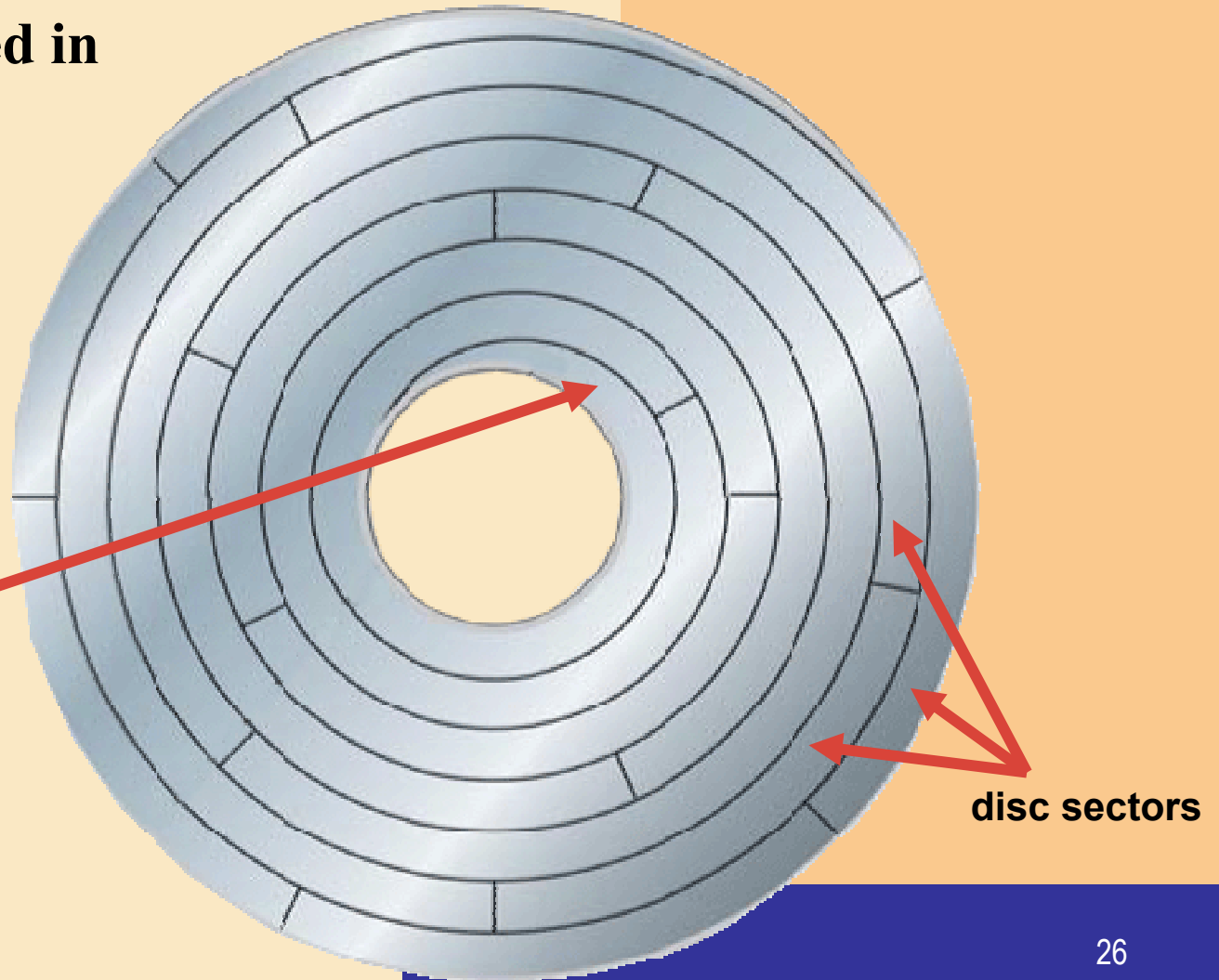

CDs and DVDs

How should you care for a CD or DVD?



Do store the disc in a jewel box when not in use



Do hold a disc by its edges

CDs and DVDs

What is a **CD-ROM**?

- **Compact disc read-only memory**
- **Cannot erase or modify contents**
- **Typically holds 650 MB to 1 GB**
- **Commonly used to distribute multimedia and complex software**



CDs and DVDs

What is the data transfer rate of a CD-ROM drive?

**Ranges from
48X to 75X
or faster**

75X

**75X is 150 KBps
(KB per second)**

**$75 \times 150 \text{ KBps} = 11,250 \text{ KBps}$
or 12.25 MBps**

**48X:
 $48 \times 150 \text{ KBps} = 7,200 \text{ KBps}$
or 7.2 MBps**

CDs and DVDs

What is a **Picture CD**?

Stores digital versions of roll of film

Film developers offer **Picture CD** service

Can be modified using photo editing software



Step 1.
Drop off film to be developed.
Mark the Picture CD box on the film-processing envelope.



Step 2.
When you pick up prints and negatives, a Picture CD contains digital images of each photograph.

Step 3.
At home, print images from Picture CD on your ink-jet photo printer.
At a store, print images to Picture CD at kiosk.

CDs and DVDs

What are **CD-Rs** and **CD-RWs**?

CD-R (compact disc-readable)
—disc you can write on once

CD-RW (compact disc-rewritable)
—erasable disc you can write on multiple times

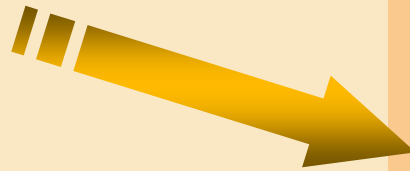
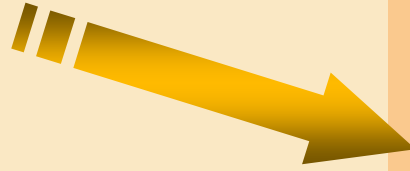
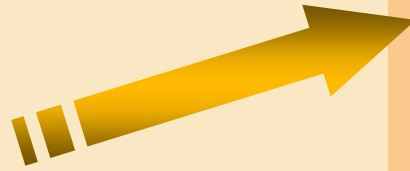

Must have **CD recorder** or **CD-R drive**

Cannot erase disc's contents

Must have **CD-RW software** and **CD-RW drive**

CDs and DVDs

How is an audio CD created?

➤ From a purchased CD...

Step 1.

Artist composes a song.



Step 2.

Song is stored on audio CD and purchased by user.



Step 5.



User listens to song on a personal computer or removes CD and listens to song on a portable CD player.

Step 4.

User copies file to a CD-RW disc.



Step 3.

User inserts audio CD into CD drive, plays song, and rips desired tracks onto hard disk.

CDs and DVDs

How is an audio CD created?

➤ From the Internet. . .

Step 1.

Artist composes a song.



Step 2.

Song is compressed and stored on the Internet.

Step 5.



User listens to song on a personal computer or removes CD and listens to song on a portable CD player.

Step 4.

User copies file to a CD-RW disc.

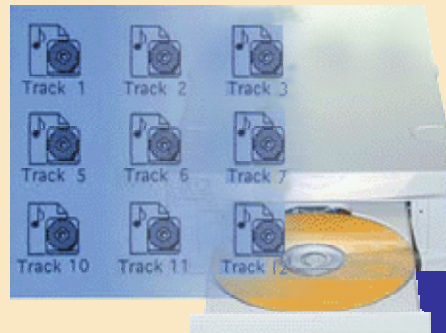

Step 3.

User pays for and downloads song as audio file onto a hard disk.

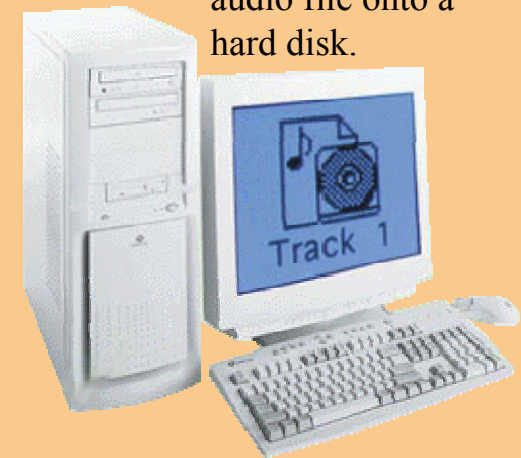

CDs and DVDs

What is a **DVD-ROM (digital versatile disc-ROM or digital video disc-ROM)**?

- High capacity disc capable of storing 4.7 GB to 17 GB
- Must have **DVD-ROM drive** or DVD player to read DVD-ROM
- Stores databases, music, complex software, and movies

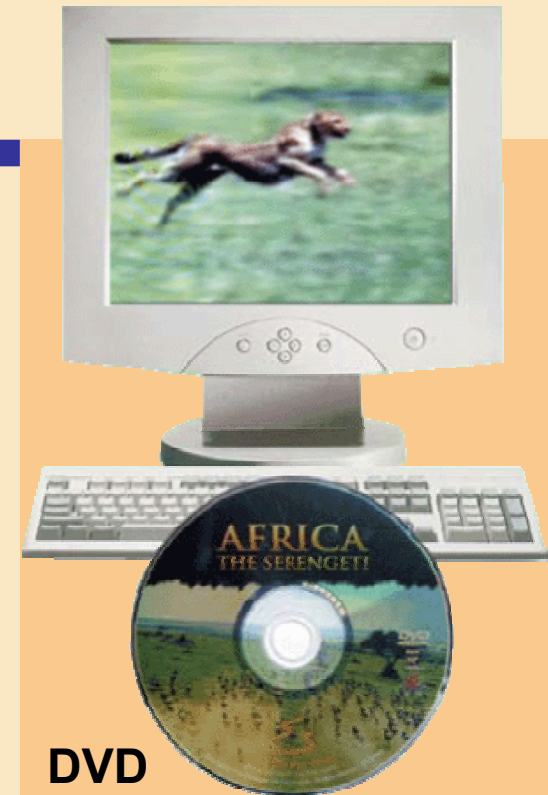

DVD

DVD drive

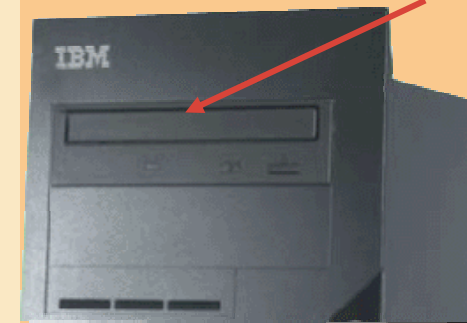

CDs and DVDs

How does a DVD-ROM store data?

- Two layers of pits are used, lower layer is semitransparent so laser can read through
- Some are double-sided
- **DVD+RW** is a rewritable DVD

DVD-ROM Storage Capacities		
Sides	Layers	Storage Capacity
1	1	4.7 GB
1	1	8.5 GB
2	1	9.4 GB
2	2	17 GB

Tape

What is **tape**?

- **Magnetically coated plastic ribbon capable of storing large amounts of data at low cost**
- **Primarily used for backup**



Tape

How is data stored on a tape?

- **Sequential access**
 - Reads and writes data consecutively, like music tape
 - Unlike **direct access** — used on floppy disks, Zip disks, hard disks, CDs, and DVDs — which can locate particular item immediately

Popular Types of Tape

Name	Abbreviation	Storage Capacity
Digital audio tape (also called digital data storage)	DAT (also called DDS)	2 GB to 240 GB
Digital linear tape	DLT	20 GB to 229 GB
Linear tape-open	LTO	100 GB to 200 GB
Quarter-inch cartridge	QIC	40 MB to 25 GB
Travan	TR	8 GB to 40 GB

PC Cards

What is a **PC Card**?

- Adds capabilities to computer
- Credit-card-sized device commonly used in notebook computers

PC Cards		
Category	Thickness	Use
Type I	3.3 mm	RAM, SRAM, flash memory
Type II	5.0 mm	Modem, LAN, SCSI, sound, TV tuner, hard disk, or other storage
Type III	10.5 mm	Rotating storage such as a hard disk



Miniature Mobile Storage Media

What is **miniature mobile storage media**?

- Storage for small mobile devices

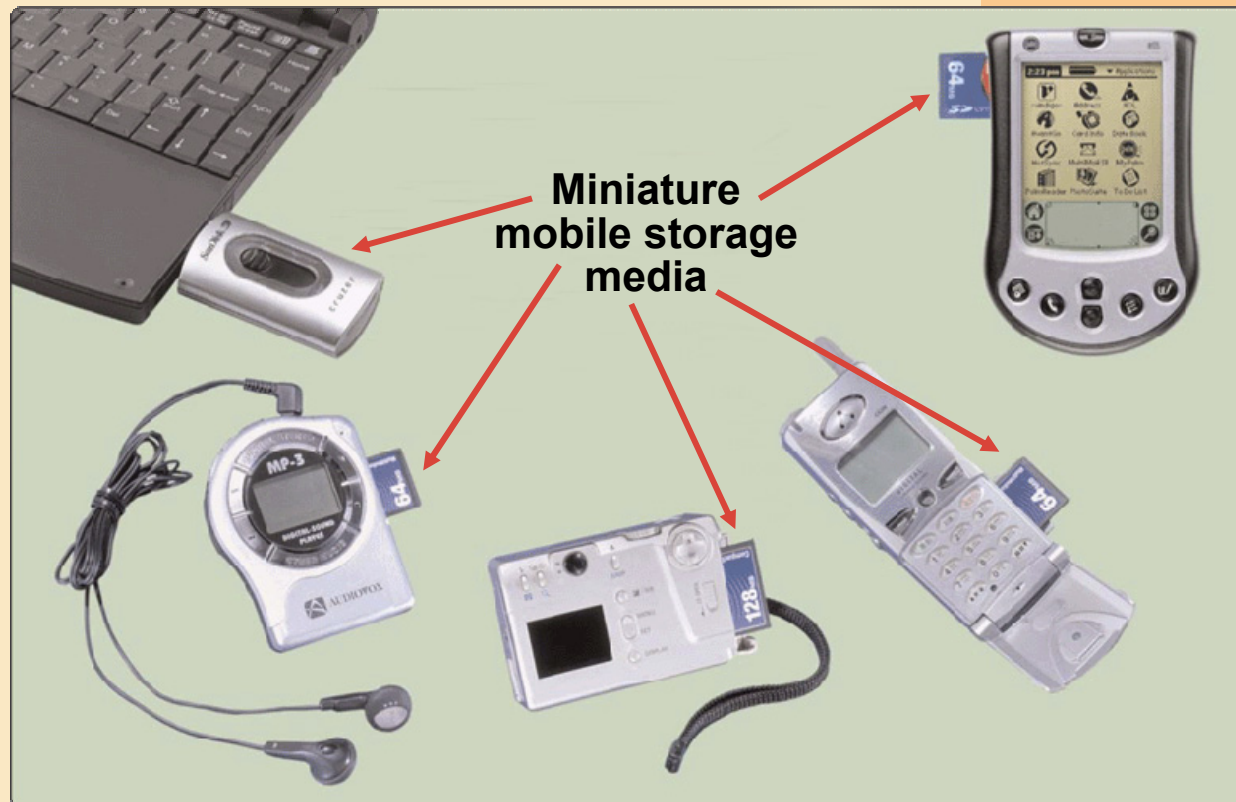

Miniature Mobile Storage Media

What are common types of miniature mobile storage media?

CompactFlash



Smart Media



Secure Digital



Memory Stick[®]



Microdrive[™]



USB Drive[™]



Miniature Mobile Storage Media

What is a **card reader**?

- Reads information stored on miniature mobile storage media
- Type of card determines type of card reader needed



Miniature Mobile Storage Media

What is a **smart card**?

- Stores data on microprocessor embedded in small card
- Input, process, output, and storage capabilities
 - Sometimes called **intelligent smart card**

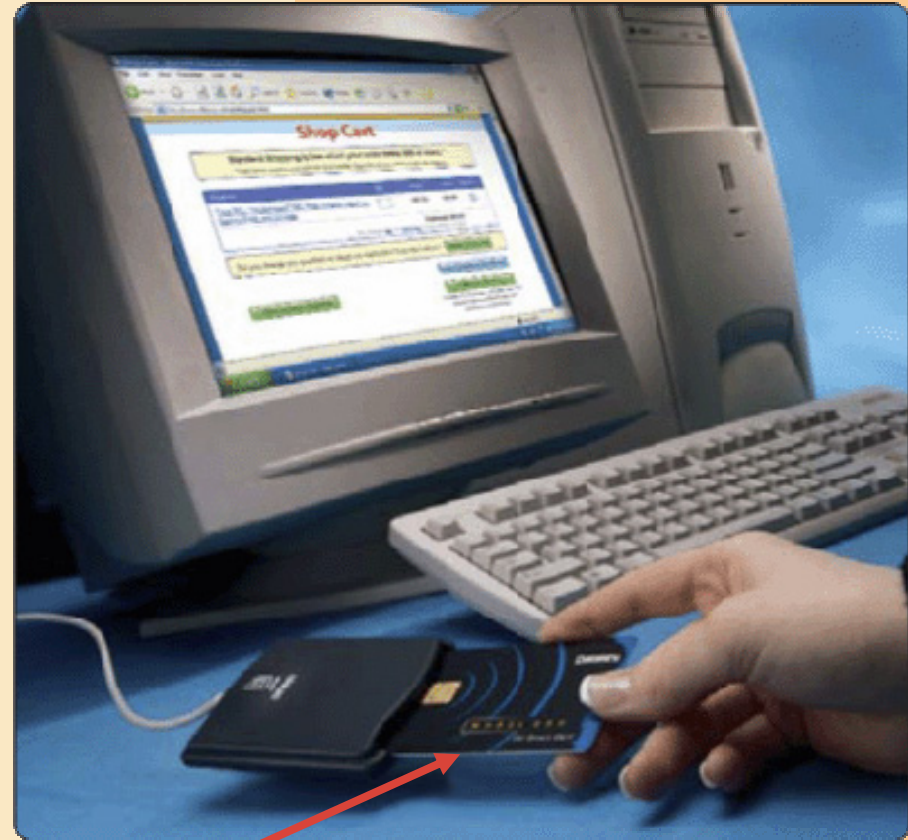

smart card

Miniature Mobile Storage Media

What is **e-money (electronic money)**?

Means of paying for
goods and services
over the Internet
Also called digital cash

Bank issues unique
digital cash numbers
that represent amount
of money

Money is withdrawn
from your bank
account

Sometimes placed
on smart card

Microfilm and Microfiche

What are **microfilm** and **microfiche**?

Store microscopic images of documents on roll or sheet of film

Images recorded using **computer output microfilm recorder**

Microfilm — 100- to 215-foot roll of film

Microfiche — small sheet of film, usually 4" × 6"



Microfilm and Microfiche

How do life expectancies of various media compare?

- Microfilm and microfiche have longest life of any storage media

Media Life Expectancies		
Media Type	Guaranteed Life Expectancy	Potential Life Expectancy
Magnetic disks	3 to 5 years	20 to 30 years
CDs and DVDs discs	5 to 10 years	50 to 100 years
Microfilm	100 years	500 years

Putting It All Together

What are recommended storage devices for home users?



Home

- 3.5-inch high-density floppy disk drive
- 250 MB Zip drive
- 60 GB hard disk
- Internet hard drive
- CD or DVD drive
- Card reader

Putting It All Together

What are recommended storage devices for small office/home office (SOHO) users?



**Small Office/
Home Office (SOHO)**

- 3.5-inch high-density floppy disk drive
- 250 MB Zip drive
- 100 GB hard disk
- Internet hard drive
- CD or DVD drive
- External hard drive for backup

Putting It All Together

What are recommended storage devices for mobile users?



Mobile

- 3.5-inch high-density floppy disk drive
- 2 GB PC Card hard disk or USB Drive
- 40 GB hard disk
- Internet hard drive
- CD or DVD drive
- Card reader
- External or removable hard disk for backup

Putting It All Together

What are recommended storage devices for large business users?



Large Business

- 3.5-inch high-density floppy disk drive
- 160 GB hard disk
- CD or DVD drive
- Microfilm or microfiche
- Smart card reader
- Tape drive

Putting It All Together

What are recommended storage devices for power users?

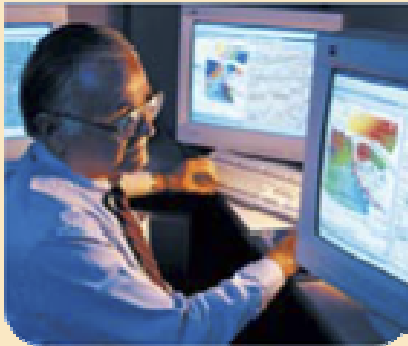

Power

- 3.5-inch high-density floppy disk drive
- CD or DVD drive
- 160 GB hard disk
- Internet hard drive
- External or removable hard disk for backup