

Lecture 2: Modulation & Demodulation without Noise

Scribe: 巫晨熙、郭彥滕

Lecture Date: 3/8, 2017

Lecturer: I-Hsiang Wang

Outline

- Recap: Basic Principle of Mod/Demod via signal space interpretation
- Baseband: Pulse Amplitude Modulation(PAM)
- Passband: Quadrature Amplitude Modulation(QAM)

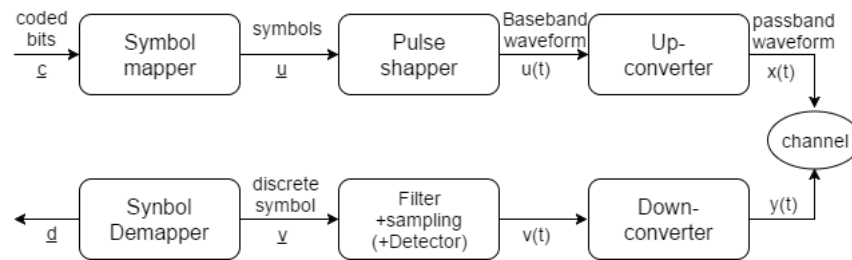

Figure 1: Block Diagram of Modulation/Demodulation

Modulation often refers to the three parts (see Fig. 1) in channel coding:

1. Symbol Mapping: convert bits to symbols
2. Pulse Shaping: convert symbol sequence to baseband waveform
3. Up Conversion: convert baseband waveform to passband waveform

The goal of this lecture is to introduce the architecture of digital modulation and demodulation, and hence the channel is assumed to be ideal. i.e) $x(t) = y(t)$, that is, no noise at all.

Recap Modulation and demodulation as synthesis and decomposition in signal space: Let $\{\phi_m(t)\}$ be an orthonormal basis of the signal space.

- Synthesis: Modulation, from symbols to waveform:

$$\{x[m]\} \rightarrow \{\phi_m\} \rightarrow x(t) = \sum_{m=-\infty}^{\infty} x[m] \cdot \phi_m(t)$$

- Decomposition: Demodulation, from waveform to symbols:

$$x(t) \rightarrow \{\phi_m(t)\} \rightarrow x[m] = \langle x(t), \phi_m(t) \rangle$$

Overview of this lecture There are infinitely possibilities in choosing $\phi_m(t)$ and the symbol mapper. In the following we introduce a particular framework that is widely used in current communication systems:

1. Bits to Symbols: Group ℓ ($\ell \geq 1$) bits together to form each symbol:

$$\therefore u_m \in \mathcal{A} \triangleq \{a_1, a_2, \dots, a_M\}, \quad M = 2^\ell, \quad \text{where } \mathcal{A} \text{ denotes the constellation set}$$

2. Symbols to Baseband Waveform: $\phi_m(t) = p(t - mT)$ for some *pulse* $p(t)$ with *transmission interval* $T = \frac{1}{2W}$ (W : 占 用 頻 寬). This is called **Pulse Amplitude Modulation (PAM)**.
3. PAM is generalized to **Quadrature Amplitude Modulation (QAM)** when we use $\cos(2\pi f_c t)$ and $\sin(2\pi f_c t)$ altogether to shift the baseband waveform to passband.

1 Pulse Amplitude Modulation (PAM)

1.1 Modulation

PAM modulation follows the synthesis formula below:

$$u(t) = \sum_{m=-\infty}^{\infty} u_m \cdot p(t - mT) \tag{1}$$

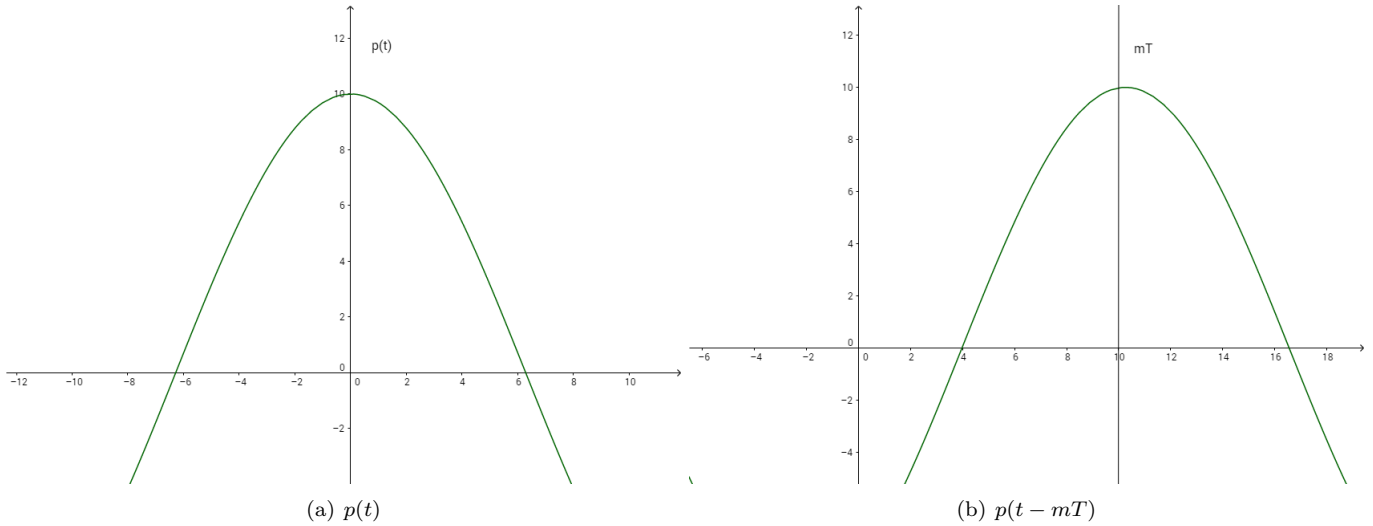

Figure 2: Illustration of Shifted Pulses in Pulse Shaping

Desired properties in choosing $p(t)$

1. $p(t) = 0, \forall t < -\tau, \tau \geq 0$ [time-limited]. Otherwise, the pulse cannot be used in practice.
 2. $\hat{p}(f) = 0, \forall f, |f| > B_b$ [band-limited]. Otherwise, the pulse easily violates physical constraints.
- Note: we use $\hat{p}(f)$ to denote the Fourier transform of $p(t)$.

1.2 Demodulation

PAM demodulation comprises filter + sampling, as depicted in the following:

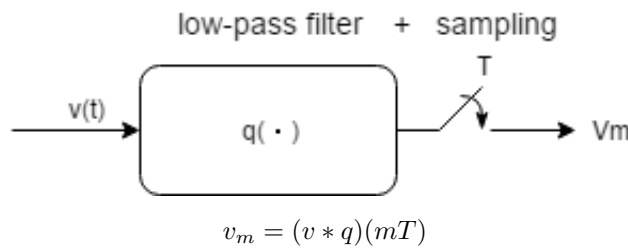

When $u(t) = v(t)$, we would like to ensure $u_m = v_m$ for all m . In the following, we derive a condition that we would like the pulse $p(t)$ and the filter $q(t)$ to satisfy.

1.2.1 ISI-free condition

Since $u(t) = \sum_k u_k p(t - kT)$, by the linearity of convolution, we have

$$v_m = (u * q)(mT) = \sum_k g(mT - kT) = \sum_k g((m - k)T),$$

where $g(t) \triangleq (p * q)(t)$. Hence, $u_m = v_m$ if

$$g(\hat{k}T) = \begin{cases} 0 & \text{if } \hat{k} \neq 0 \\ 1 & \text{if } \hat{k} = 0 \end{cases} = \delta_{\hat{k}}$$

Definition 1 (Ideal Nyquist). We say $g(t)$ is ideal Nyquist with interval T if the above condition holds, that is, $g(kT) = \delta_k$. In other words, if the pulse p and the filter q are chosen such that $g = p * q$ is ideal Nyquist with interval T , then there is no inter-symbol interference (ISI), that is, the recovered $v_m = u_m$ when $v(t) = u(t)$.

Combined with the time-limited and band-limited properties of $p(t)$, the desired properties for $g(t)$ are the following:

1. $p(t) = 0, \forall t < -\tau, \tau \geq 0$ [time-limited].
2. $\hat{p}(f) = 0, \forall f, |f| > B_b$ [band-limited].
3. $g(t)$ is ideal Nyquist with interval T .

Remark It is impossible to have “time-limited” and “band-limited” simultaneously. In practice, frequency-domain constraints are usually more stringent. Hence, we keep band-limitedness but replace time-limitedness by *approximately* time-limited, that is, $p(t) \rightarrow 0$ rapidly as $t \rightarrow -\infty$. When we implement the pulse, usually the pulse $p(t)$ is truncated, that is, the wave form is set to zero for all $t < -\tau$ for some $\tau \geq 0$. This truncation process will introduce additional error and result in noise effectivly. Hence, the faster $p(t) \rightarrow 0$, the less noisy it will be.

1.2.2 Nyquist criterion

Let’s introduce a simple equivalent condition in the frequency-domain for checking ideal Nyquist.

Theorem 2. $g(t)$ is ideal Nyquist with interval T if and only if its frequency domain response $\hat{g}(f)$ satisfies the following Nyquist Criterion:

$$T \text{rect}(fT) = \sum_m \hat{g}(f - \frac{m}{T}) \text{rect}(fT), \tag{2}$$

where the function $\text{rect}(fT)$ is depicted below.

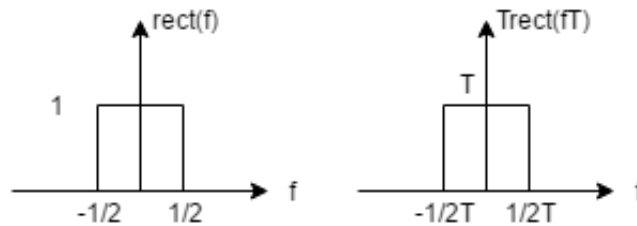

1.2.3 Example pulses

1. Sinc Pulse: $g(t) = \text{sinc}(\frac{t}{T}), \hat{g}(f) = T \text{rect}(fT)$.
2. Raised Cosine Pulse: $g_\beta(t) = \text{sinc}(\frac{t}{T}) \frac{\cos(\frac{\pi\beta t}{T})}{1-4\beta^2 t^2 T}$,

$$\hat{g}_\beta(f) = \begin{cases} T & \text{if } |f| \leq \frac{1-\beta}{2T} \\ 0 & \text{if } |f| > \frac{1+\beta}{2T} \\ T \cos^2(\frac{\pi T}{2\beta} (|f| - \frac{1-\beta}{2T})) & \text{if } \frac{1-\beta}{T} < |f| \leq \frac{1+\beta}{T} \end{cases}$$

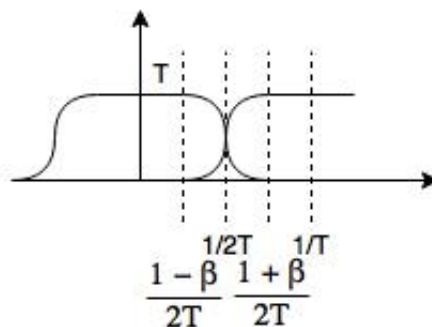

1.2.4 Band-edge symmetry and excessive bandwidth

The effective bandwidth W is usually strictly smaller than the actual bandwidth B_b , to allow smoother transition in the frequency domain so that the pulse vanishes to zero faster. Hence, the excessive bandwidth is defined as $B_b - W$.

On the other hand, we do not want to make $B_b - W$ too large. A typical choice for the effective bandwidth B is to satisfy $W \leq B_b \leq 2W$. In this case, one can easily verify the Nyquist Criterion (2) becomes the following *band-edge symmetry* condition:

$$T - \hat{g}(W_b + \Delta) = \hat{g}^*(W_b - \Delta), \quad \forall \Delta \in [0, W_b] \tag{3}$$

(check!) See the illustration below.

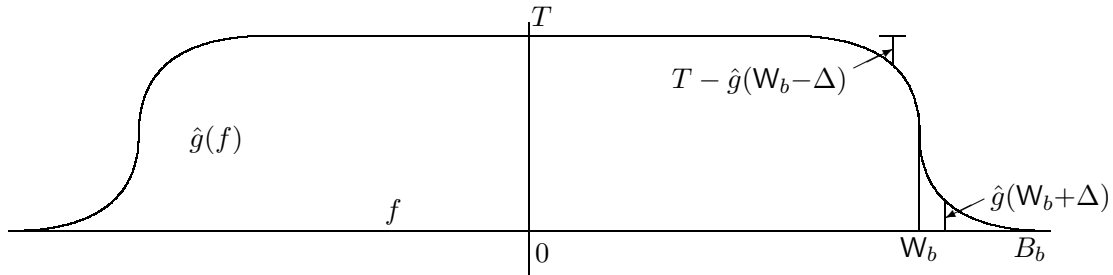

You can easily check that sinc pulse and raise-cosine pulse all satisfy the band-edge symmetry condition (3).

1.2.5 A simple way to choose $p(t)$ and $q(t)$ give $g(t)$

Since $\hat{g}(f) = \hat{p}(f) \cdot \hat{q}(f)$, we can simply choose $|\hat{p}(f)| = |\hat{q}(f)| = \sqrt{\hat{g}(f)}$. With this choice, we have the following nice theorem relating ISI-free condition and orthogonality:

Theorem 3. Suppose $\hat{g}(f) = |\hat{p}(f)|^2$ and satisfies the Nyquist Criterion with interval T . Then, $\{p(t - mT) : m \in \mathbb{Z}\}$ form an orthonormal set. Conversely, if $\{p(t - mT) : m \in \mathbb{Z}\}$ form an orthonormal set, then $|\hat{p}(f)|^2$ satisfies the Nyquist Criterion.

Summary:

1. $\hat{p}(f) = \hat{q}^*(f)$ (phase offset)
2. $|\hat{p}(f)|^2$ satisfies Nyquist Criterion
3. If $p(t) \in \mathbb{R}$ (which is normally the case), then $\hat{q}(f) = \hat{p}^*(f) = \hat{p}(-f)$ and hence $q(t) = p(-t)$.
4. For faster decay in the time-domain (less approximation error) in $t \implies$ need “larger room” for smoother transition from T to 0 in the frequency-domain

2 Quadrature Amplitude Modulation (QAM)

Prelude: How to move signal from baseband to passband?

Recall: a *passband* signal occupies a frequency band with a center frequency f_c in the frequency domain.

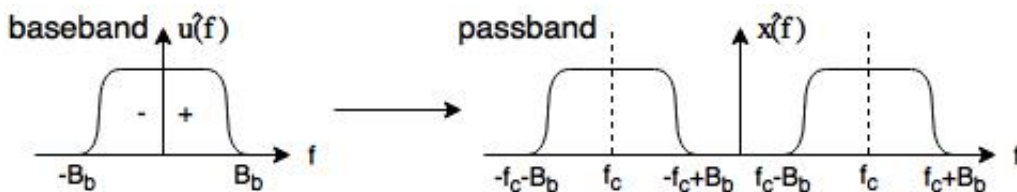

A simple way:

$$x(t) = u(t) \cdot (e^{j2\pi f_c t} + e^{-j2\pi f_c t}) = 2u(t) \cdot \cos(2\pi f_c t)$$

$$\hat{x}(f) = \hat{u}(f - f_c) + \hat{u}(f + f_c)$$

This is called *double-sideband amplitude modulation*. However, this is a waste of frequency resource because $u(t)$ is real and the “+” & “-” can be inferred from one another.

Idea: Make $u(t)$ complex. Mathematically,

$$u(t) = u^{(I)}(t) + ju^{(Q)}(t)$$

$$x(t) = u(t)e^{j2\pi f_c t} + u^*(t)e^{-j2\pi f_c t} = 2\text{Re}\{u(t) \cdot e^{j2\pi f_c t}\} = 2u^{(I)}(t) \cos(2\pi f_c t) - 2u^{(Q)}(t) \sin(2\pi f_c t)$$

2.1 Modulation

2.1.1 Complex view

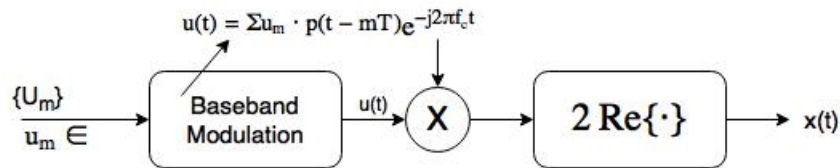

2.1.2 Real view

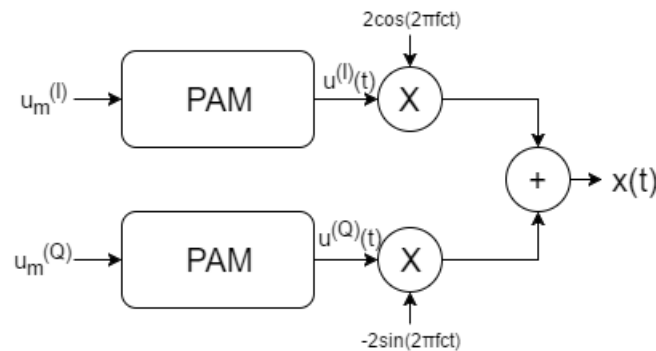

2.2 Demodulation

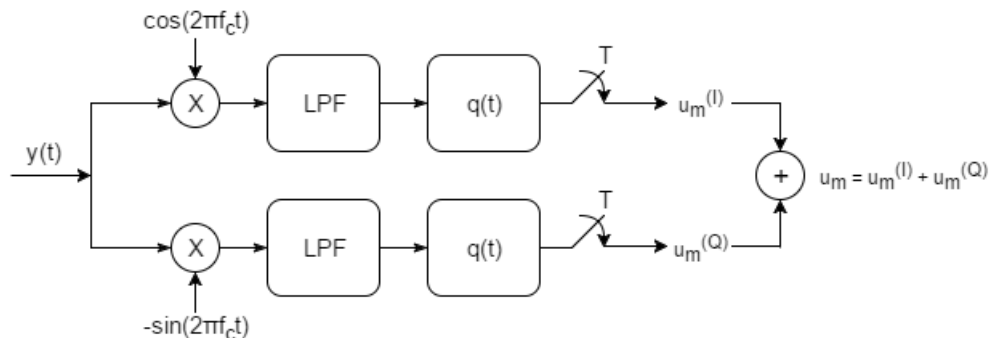

Remark The above *equivalent complex baseband representation* for the real passband signals/filters are very useful. We will adopt this representation and think of symbols taking values in the complex domain hereafter.

3 Design of Constellation Set and Symbol Mapping

The constellation set $\mathcal{A} = \{a_1, a_2, \dots, a_M\}$ is a subset of $M = 2^\ell$ constellation points in the complex plane. The main design question is, how to put these M points on the plane.

It turns out the design largely determines the performance of demodulation when noise is present, that is, the channel is not perfect anymore. How to do demodulation in the presence of noise, called *detection*, will be discussed in the next couple of lectures.

For this lecture, we introduce several common constellation sets, along with a popular mapping rule called *Gray mapping*.

Definition 4 (Gray Mapping). *Gray mapping assign the 2^ℓ possible combinations of ordered ℓ bits to constellation points in a way such that there is only one-bit difference between nearest-neighboring points.*

3.1 Example: $\ell = 2$

For $\ell = 2$, we group 2 bits to form a symbol, and hence $\mathbb{A} = \{a_1, a_2, a_3, a_4\}$.

1. PAM constellation set: A standard way is to place $a_1, a_2, \dots, a_{2^\ell}$ on the real line “equally spaced” and symmetric to the origin.

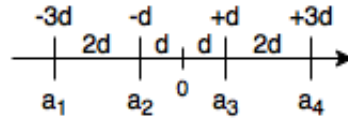

2. (Standard) QAM constellation set: similar to PAM, but on the complex plane:

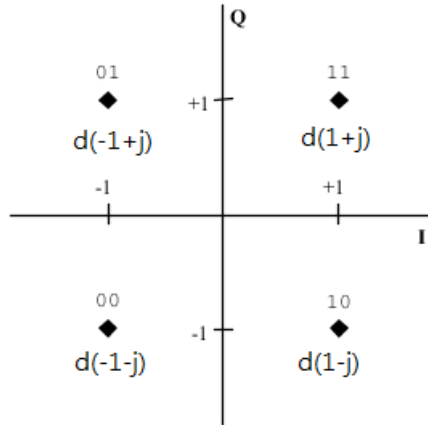

QAM can be viewed as the direct product of two PAM, one in the real axis and the other in the imaginary axis. For example, 16-QAM constellation set:

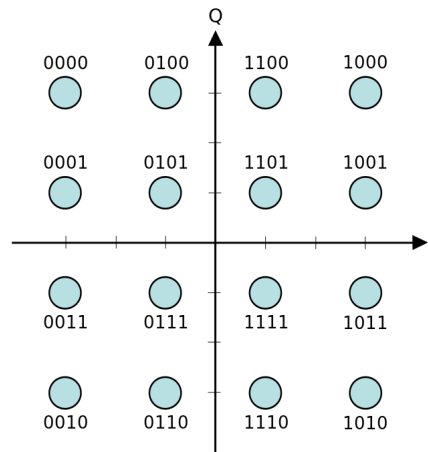

3. PSK (Phase-Shift Keying) constellation set: information is embedded on the phase of the signal. For $\ell = 3, \mathcal{A} = \{a_1, a_2, \dots, a_8\}$:

