

Control System: Homework 01 for Unit 2: Dynamic Models

Assigned: Sep 23, 2022

Due: Sep 29, 2022 (23:59)

Please read the following problems and their solutions. Then, choose one of them and edit your solution for the selected problem. Submit your homework file in PDF format to the NTU-Cool website.

1. (Mechanical systems)

2.8 In many mechanical positioning systems there is flexibility between one part of the system and another. An example is shown in Fig. 2.7 where there is flexibility of the solar panels. Figure 2.44 depicts such a situation, where a force u is applied to the mass M and another mass m is connected to it. The coupling between the objects is often modeled by a spring constant k with a damping coefficient b , although the actual situation is usually much more complicated than this.

(a) Write the equations of motion governing this system.

(b) Find the transfer function between the control input u and the output y .

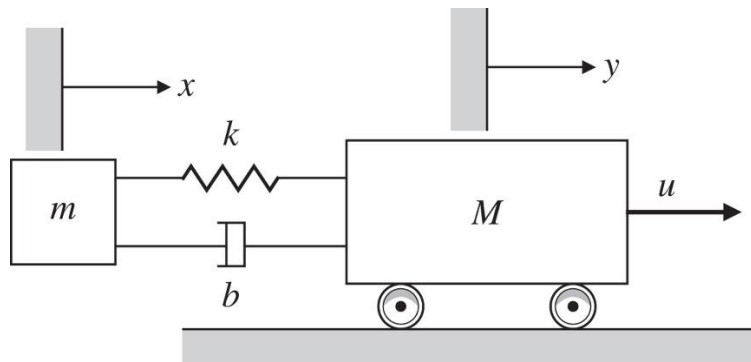
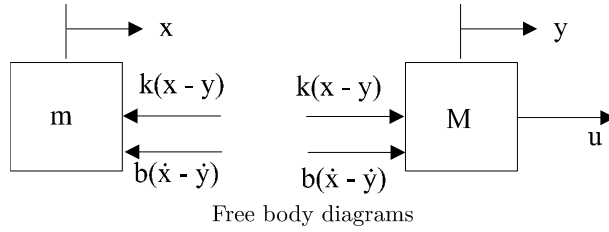

Figure 2.44 Schematic of a system with flexibility

Solution:

(a) The FBD for the system is



which results in the equations

$$\begin{aligned} m\ddot{x} &= -k(x-y) - b(\dot{x}-\dot{y}) \\ M\ddot{y} &= u + k(x-y) + b(\dot{x}-\dot{y}) \end{aligned}$$

or

$$\begin{aligned} \ddot{x} + \frac{k}{m}x + \frac{b}{m}\dot{x} - \frac{k}{m}y - \frac{b}{m}\dot{y} &= 0 \\ -\frac{k}{M}x - \frac{b}{M}\dot{x} + \ddot{y} + \frac{k}{M}y + \frac{b}{M}\dot{y} &= \frac{1}{M}u \end{aligned}$$

(b) If we make Laplace Transform of the equations of motion

$$\begin{aligned} s^2X + \frac{k}{m}X + \frac{b}{m}sX - \frac{k}{m}Y - \frac{b}{m}sY &= 0 \\ -\frac{k}{M}X - \frac{b}{M}sX + s^2Y + \frac{k}{M}Y + \frac{b}{M}sY &= \frac{1}{M}U \end{aligned}$$

In matrix form,

$$\begin{bmatrix} ms^2 + bs + k & -(bs + k) \\ -(bs + k) & Ms^2 + bs + k \end{bmatrix} \begin{bmatrix} X \\ Y \end{bmatrix} = \begin{bmatrix} 0 \\ U \end{bmatrix}$$

From Cramer's Rule,

$$\begin{aligned} Y &= \frac{\det \begin{bmatrix} ms^2 + bs + k & 0 \\ -(bs + k) & U \end{bmatrix}}{\det \begin{bmatrix} ms^2 + bs + k & -(bs + k) \\ -(bs + k) & Ms^2 + bs + k \end{bmatrix}} \\ &= \frac{ms^2 + bs + k}{(ms^2 + bs + k)(Ms^2 + bs + k) - (bs + k)^2} U \end{aligned}$$

Finally,

$$\begin{aligned} \frac{Y}{U} &= \frac{ms^2 + bs + k}{(ms^2 + bs + k)(Ms^2 + bs + k) - (bs + k)^2} \\ &= \frac{ms^2 + bs + k}{mMs^4 + (m + M)bs^3 + (M + m)ks^2} \end{aligned}$$

2. (Electric Circuits)

2.13 A common connection for a motor power amplifier is shown in Fig. 2.49. The idea is to have the motor current follow the input voltage, and the connection is called a current amplifier. Assume that the sense resistor r_s is very small compared with the feedback resistor R , and find the transfer function from V_{in} to I_a . Also show the transfer function when $R_f = \infty$.

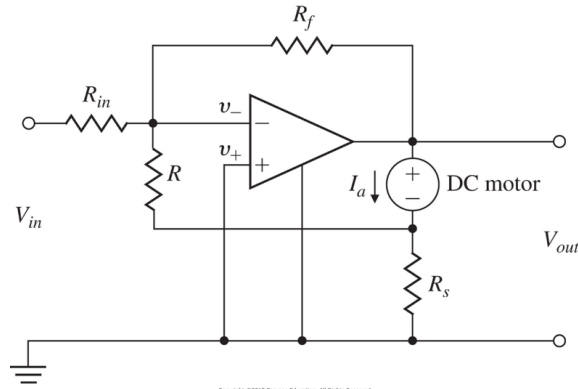

Figure 2.49 Op-amp circuit for Problem 2.13

Solution:

At node A,

$$\frac{V_{in} - 0}{R_{in}} + \frac{V_{out} - 0}{R_f} + \frac{V_B - 0}{R} = 0 \quad (93)$$

At node B, with $R_s \ll R$

$$I_a + \frac{0 - V_B}{R} + \frac{0 - V_B}{R_s} = 0 \quad (94)$$

$$V_B = \frac{RR_s}{R + R_s} I_a$$

$$V_B \approx R_s I_a$$

The dynamics of the motor is modeled with negligible inductance as

$$J_m \ddot{\theta}_m + b \dot{\theta}_m = K_t I_a \quad (95)$$

$$J_m s \Omega + b \Omega = K_t I_a$$

At the output, from Eq. 94, Eq. 95 and the motor equation $V_a = I_a R_a + K_e s \Omega$

$$\begin{aligned} V_o &= I_a R_s + V_a \\ &= I_a R_s + I_a R_a + K_e \frac{K_t I_a}{J_m s + b} \end{aligned}$$

Substituting this into Eq.93

$$\frac{V_{in}}{R_{in}} + \frac{1}{R_f} \left[I_a R_s + I_a R_a + K_e \frac{K_t I_a}{J_m s + b} \right] + \frac{I_a R_s}{R} = 0$$

This expression shows that, in the steady state when $s \rightarrow 0$, the current is proportional to the input voltage.

If fact, the current amplifier normally has no feedback from the output voltage, in which case $R_f \rightarrow \infty$ and we have simply

$$\frac{I_a}{V_{in}} = -\frac{R}{R_{in} R_s}$$

3. (Electromechanical Systems)

2.19 The electromechanical system shown in Fig. 2.53 represents a simplified model of a capacitor microphone. The system consists in part of a parallel plate capacitor connected into an electric circuit. Capacitor plate a is rigidly fastened to the microphone frame. Sound waves pass through the mouthpiece and exert a force $f_s(t)$ on plate b , which has mass M and is connected to the frame by a set of springs and dampers. The capacitance C is a function of the distance x between the plates, as follows:

$$C(x) = \frac{\epsilon A}{x},$$

where

ϵ = dielectric constant of the material between the plates,

A = surface area of the plates.

The charge q and the voltage e across the plates are related by

$$q = C(x)e.$$

The electric field in turn produces the following force f_e on the movable plate that opposes its motion:

$$f_e = \frac{q^2}{2\epsilon A}.$$

- Write differential equations that describe the operation of this system. (It is acceptable to leave in nonlinear form.)
- Can one get a linear model?
- What is the output of the system?

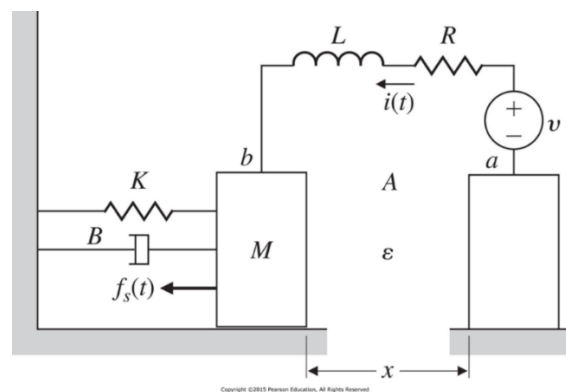
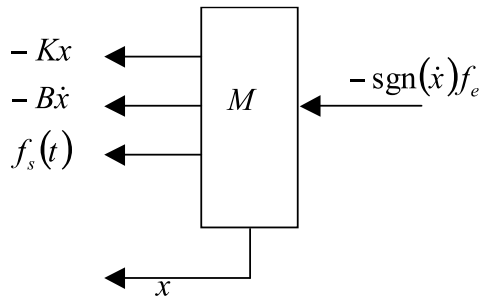

Figure 2.53 Simplified model for capacitor microphone

Solution:

(a) The free body diagram of the capacitor plate b



Free body diagram

So the equation of motion for the plate is

$$M\ddot{x} + B\dot{x} + Kx + f_e \text{sgn}(\dot{x}) = f_s(t).$$

The equation of motion for the circuit is

$$v = iR + L\frac{d}{dt}i + e$$

where e is the voltage across the capacitor,

$$e = \frac{1}{C} \int i(t) dt$$

and where $C = \epsilon A/x$, a variable. Because $i = \frac{d}{dt}q$ and $e = q/C$, we can rewrite the circuit equation as

$$v = R\dot{q} + L\ddot{q} + \frac{qx}{\epsilon A}$$

In summary, we have these two, coupled, non-linear differential equation.

$$\begin{aligned} M\ddot{x} + b\dot{x} + kx + \text{sgn}(\dot{x}) \frac{q^2}{2\epsilon A} &= f_s(t) \\ R\dot{q} + L\ddot{q} + \frac{qx}{\epsilon A} &= v \end{aligned}$$

(b) The sgn function, q^2 , and qx , terms make it impossible to determine a useful linearized version.

(c) The signal representing the voice input is the current, i , or \dot{q} .