

Spring 2021

控制系統
Control Systems

Unit 1A
Introduction - Feedback and Control

Feng-Li Lian

NTU-EE

Feb 2021 – Jun 2021

- AlphaGo (圍棋)
- 人的手下棋



- 機械手下棋



- CoViD – 19 (新型冠狀病毒肺炎)
- 即時口罩地圖 <https://mask.goodideas-studio.com/>



■ 口罩自動化生產系統



https://youtu.be/DCee9sSA_mY
<https://youtu.be/UB0gEHqc1GI>

udn / 僑匯家 / 新社會

看見我科技實力！唐鳳：多國對台灣口罩地圖有興趣
2020/02/18 張文馨

行政院政務委員唐鳳受華府智庫邀請訪問美國，他14日在駐美代表處分享此行訪問經驗；被問到新冠肺炎 (COVID-19) 在台灣造成口罩短缺，唐鳳說，台灣轉此機會作開放政策，把原本碼放在網路上成立口罩地圖，引起美國等國家的興趣，他們都可以直接從網路上看到這次製作過程。



行政院政務委員唐鳳。圖 / 黃仲裕攝影

唐鳳指出，此行也有和美國國會與行政機關官員互動，和美國國會參議院物聯網連線的主席、金融服務小組委員會、人工智慧任務小組主席，以及行政機關的數位任務小組成員聊到欲罷不能。談話毫無開放政府、唐鳳稱，與行政官員深入交換意見，並探討可以如何合作。



網曝醫療口罩製造秘辛：2禮拜開60生產線要跪哭了

新頭殼 12k 人追蹤 追蹤
新頭殼 newtalk 洪翠聲 綜合報導
2020年2月15日 下午5:14 @ 414 則留言



行政院長蘇貞昌(左)14日視察口罩生產工廠，表示最快月底，口罩產能將可達每日產千萬片。圖：新頭殼資料照/林鈺真攝

[新頭殼newtalk] 中國武漢肺炎疫情發燒，全球口罩需求供不應求，行政院長蘇貞昌視察口罩工廠時指出，2月底或3月初，產能可拉高到每日千萬片，台灣將成全球第2大口罩生產國。對此，有網友加碼爆料，指製造低價低利醫療用口罩的產業，早在20多年前就外移，經濟部此次2個禮拜就開出60條生產線，台灣人真的要跪下來哭了，謝謝再謝謝！

網友「Ann Chang」在臉書曝光「怎麼生產醫療用口罩？」，指出3層厚的醫療用口罩最重要的是不讓布那一層，利用不讓布防水的特性阻隔飛沫傳遞，而製作時必須採用超音波震動，將布料的四邊熱熔密合，才能達到醫療用防止傳染的要求。

CoViD - 19 (新型冠狀病毒肺炎)

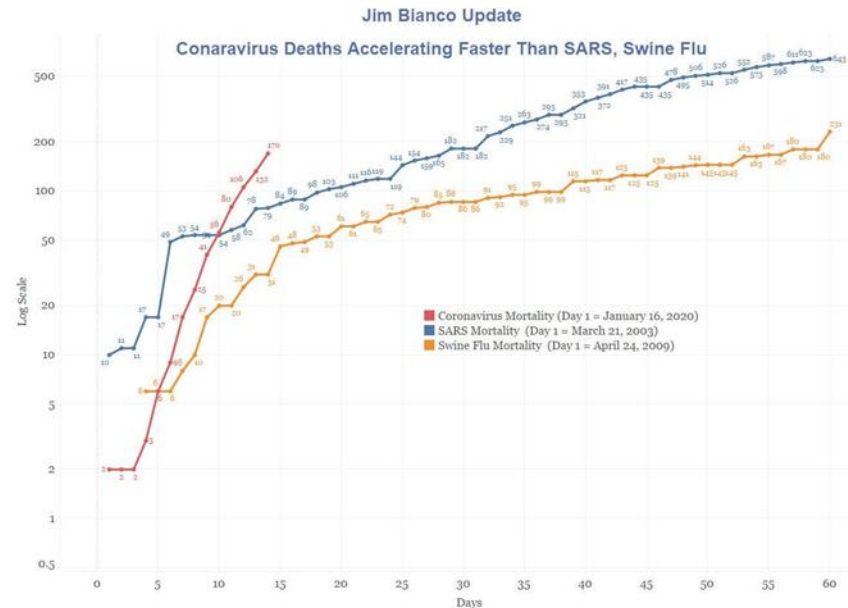
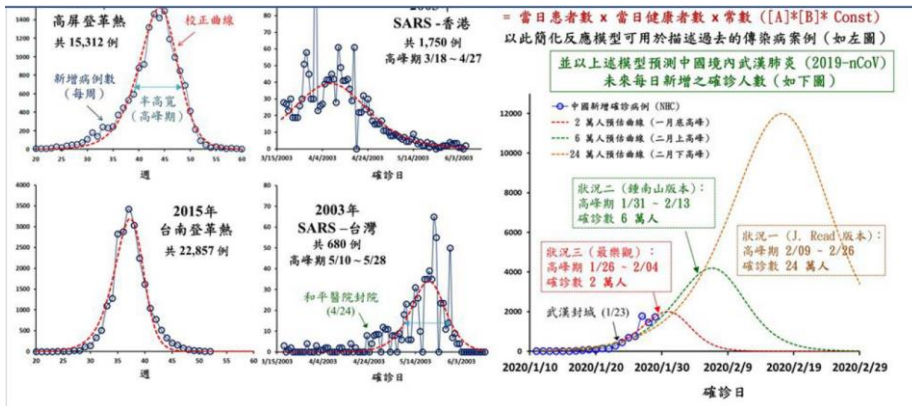
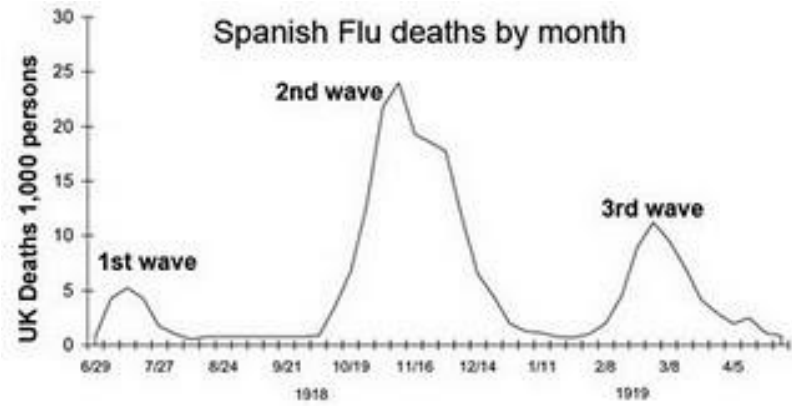

- CoViD – 19 (新型冠狀病毒肺炎)
- 馬偕醫學院 學務長 張南驥教授

流感



武漢肺炎

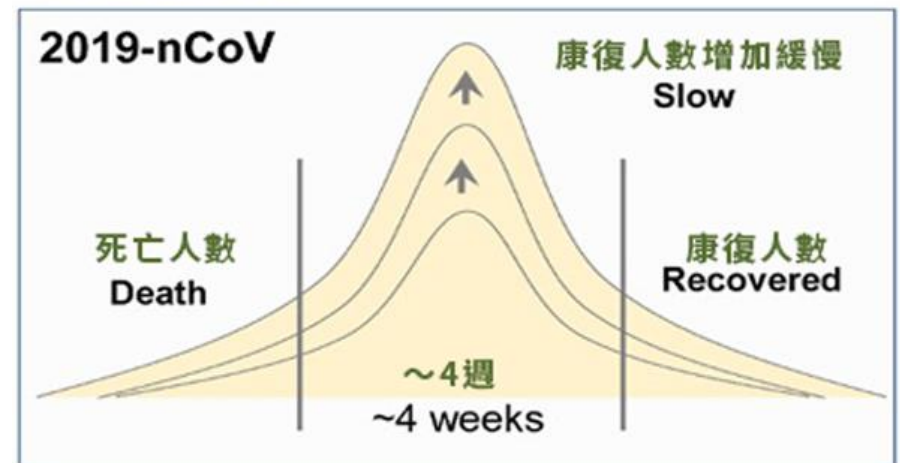

Prey-Predatory (兔子與狐狸)

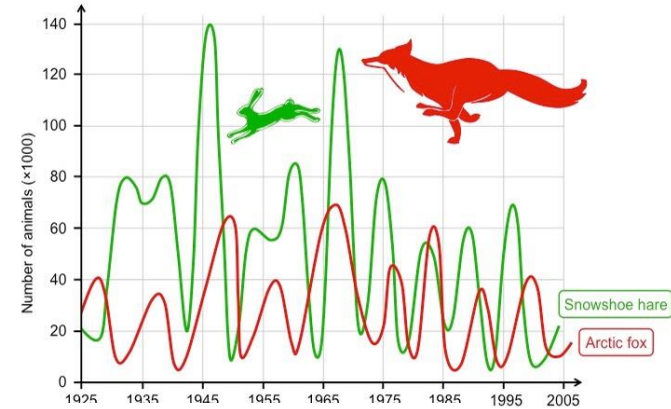

Sylvia S Mader, Biology, 6th edition. © 1998 The McGraw-Hill Companies, Inc. All rights reserved.

Comparison of Prey and Predators' Populations

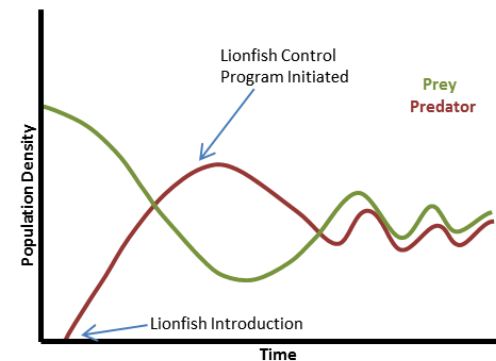
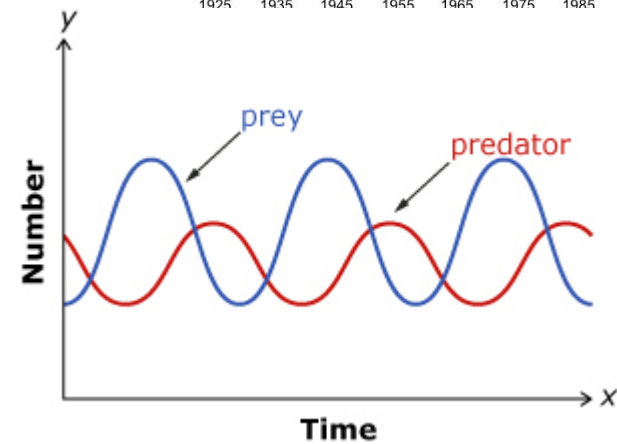
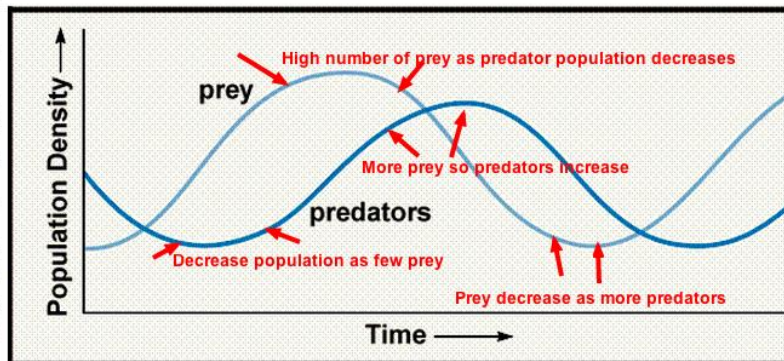

Prey-Predatory (兔子與狐狸)

VOL. 176, NO. 5 THE AMERICAN NATURALIST NOVEMBER 2010

E-ARTICLE

Understanding Rapid Evolution in Predator-Prey Interactions Using the Theory of Fast-Slow Dynamical Systems

Michael H. Cortez^{1,*} and Stephen P. Ellner^{1,2}

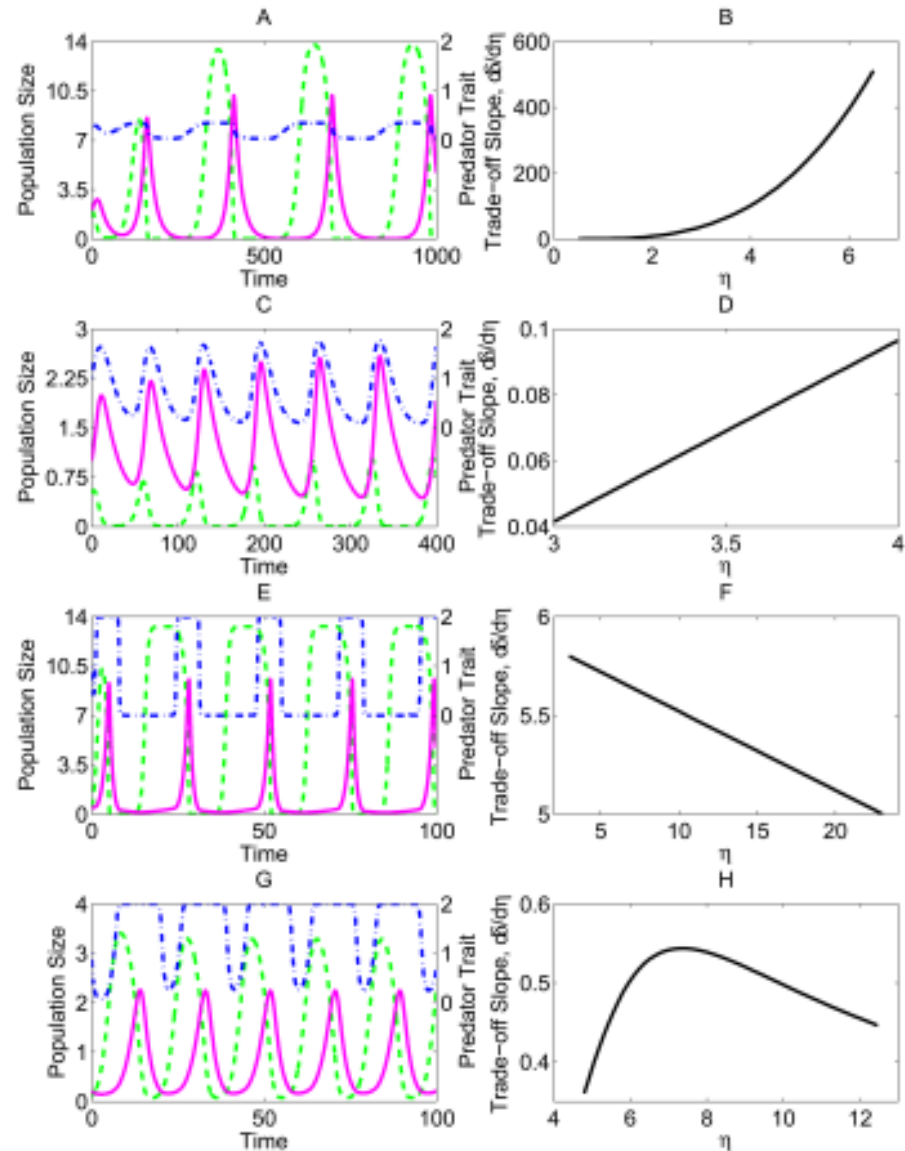
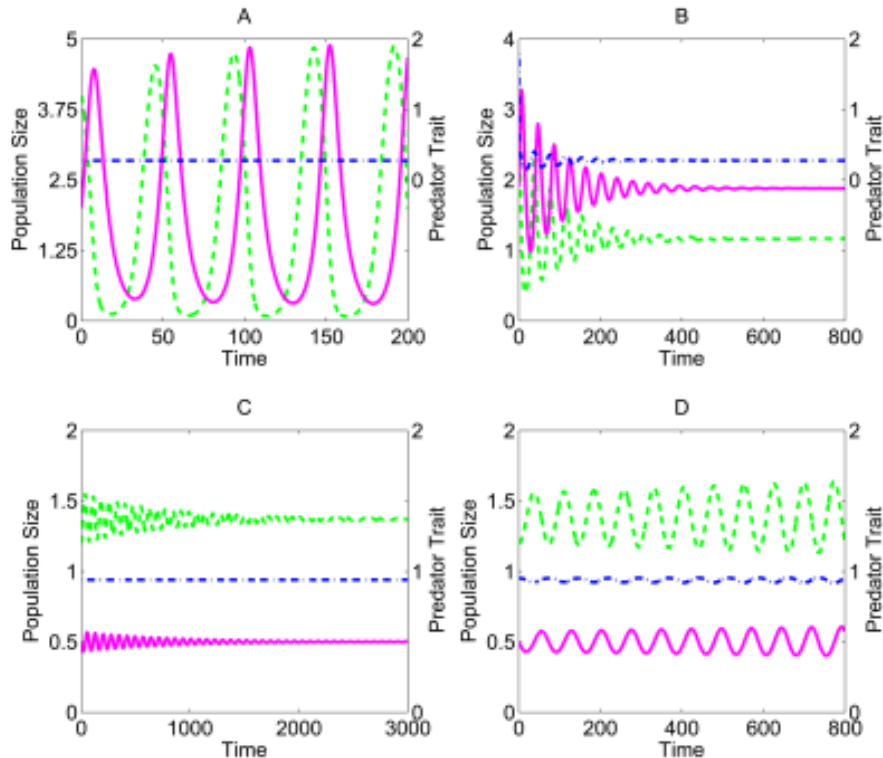

Prey-Predatory (兔子與狐狸)

Resilience Modeling by Means of a Set of Recursive Functions.

Maria Teresa Signes Pont, Juan Manuel García Chamizo, Higinio Mora Mora, Jerónimo Mora Pascual
Departamento de Tecnología Informática y Computación
Universidad de Alicante
03690 San Vicente del Raspeig - Alicante, España
[@dtic.ua.es](mailto:{teresa_juanma_hmora_jeronimo}@dtic.ua.es)

978-1-4799-0181-4/13/\$31.00 ©2013 IEEE

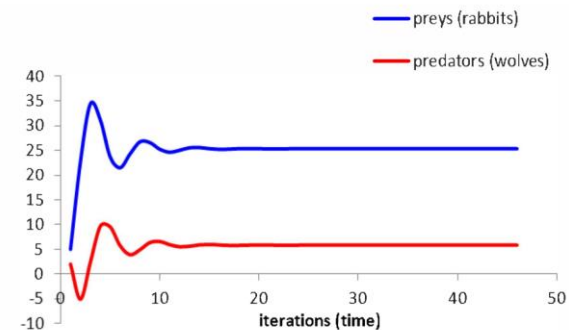
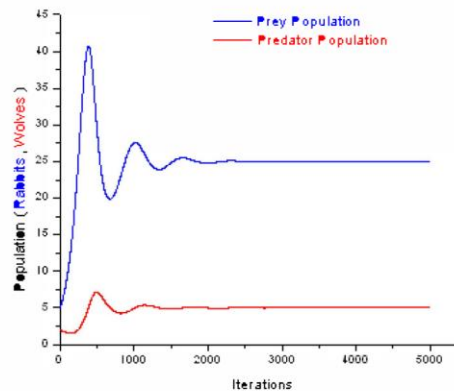
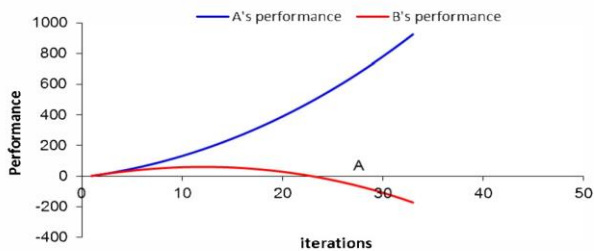
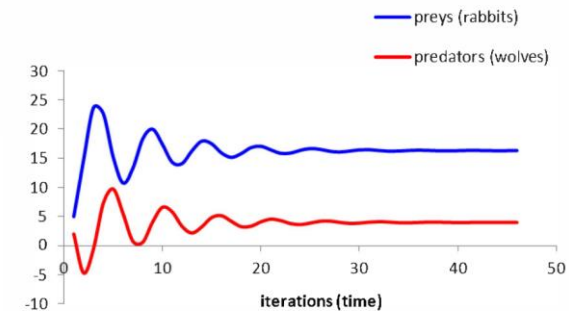
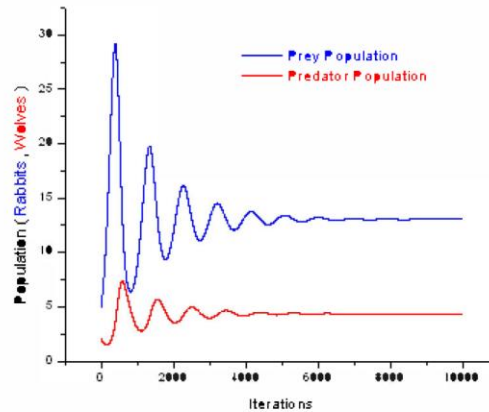
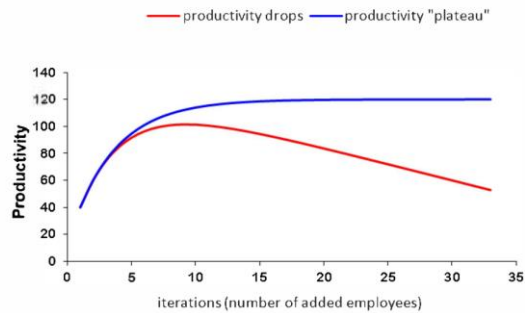
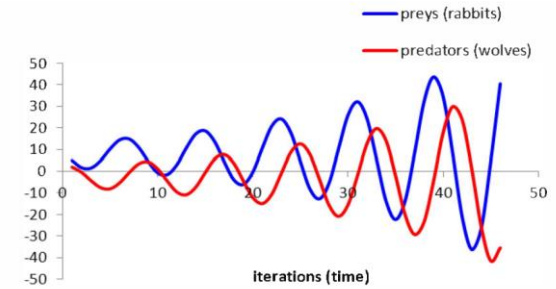
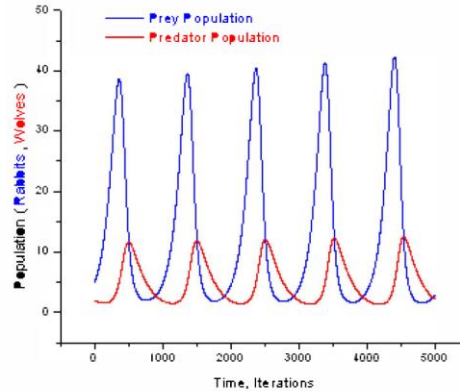

Understand the System by Differential Equations

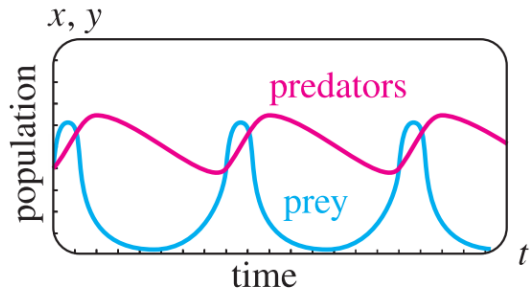

$$\frac{dx}{dt} = -0.16x + 0.08xy$$

$$\frac{dy}{dt} = 4.5y - 0.9xy$$

$$\frac{d^2x}{dt^2} + 2\lambda \frac{dx}{dt} + \omega^2 x = 0,$$

$$\frac{d^2x}{dt^2} + 2\lambda \frac{dx}{dt} + \omega^2 x = F(t),$$

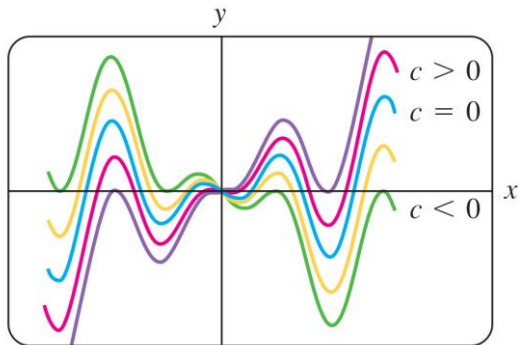
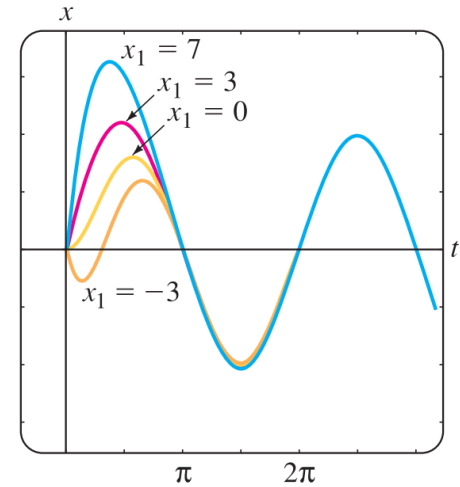
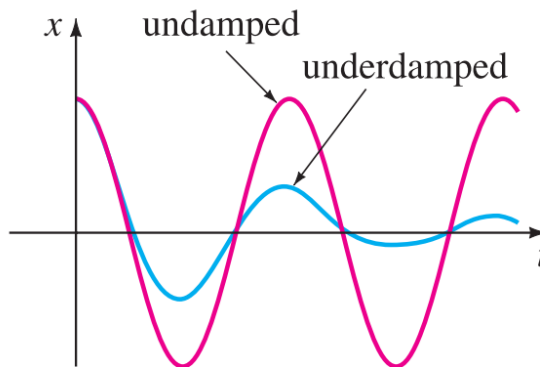
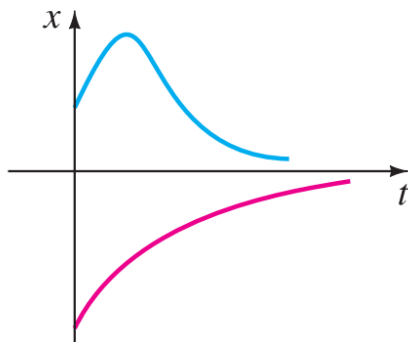
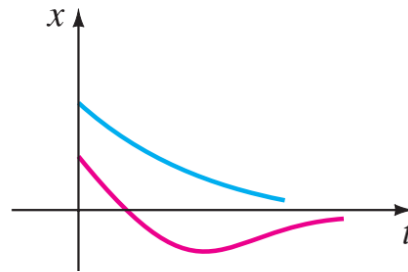

$$xy' - y = x^2 \sin x$$

$$y = cx - x \cos x$$

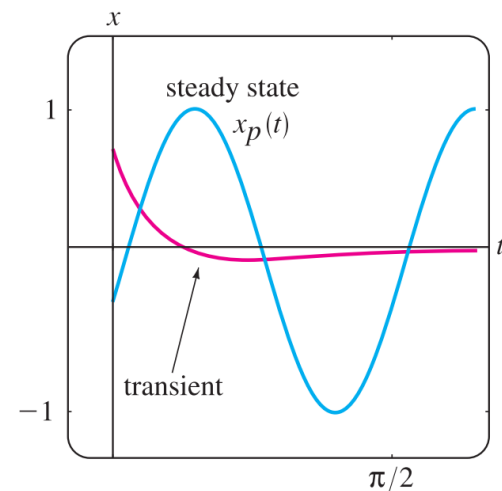



■ Google Self-Driving Cars in 2014



■ 2020年的交通與生活 Toyota e-Palette



DPCcars

Source: <https://www.youtube.com/watch?v=XmoPQuMIOYE>
<https://www.servicejdc.com/product/blog/item/60-20181015.html>

- Olympic Winter Games by Intel
- 2,000 Drones in Shanghai to Welcome New Year
- 2020 義大世界跨年夜《400台無人機視覺超震撼》
- 2020 台灣燈會無人機展演



<https://youtu.be/elk6j6dprnA>

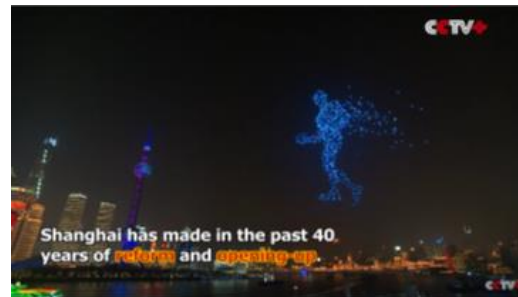

<https://youtu.be/v05uHuJj7Hs>



<https://youtu.be/XS--SQMUeUY>



<https://news.ltn.com.tw/news/life/breakingnews/3077228>



<https://youtu.be/XTUS3cfKUuc>

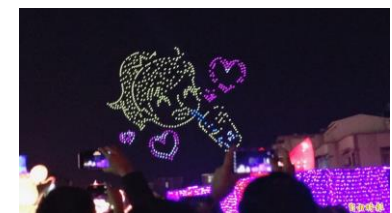

■ Top Layer:

- For Multiple Agents (Group of Vehicles, Cars, Drones)



<https://images.app.goo.gl/Zvqbjf3nsAFoLBFK8>



<https://images.app.goo.gl/FjoqLo13CQ8o4v83A>



<https://images.app.goo.gl/A9yhHUUEsoJKWPLj9>



<https://images.app.goo.gl/ErUGddRBXwdwr2b17>

● Action:

- 方向盤
- 油門煞車

● Goal:

- 位置/車道
- 速度/方向

■ Middle Layer:

- For Single Agent (Single Vehicle, Car, Drone)



<https://images.app.goo.gl/pSfjDpcyaSnPEb6t7>



<https://images.app.goo.gl/9MnAPBzcBDJcpxiQ6>

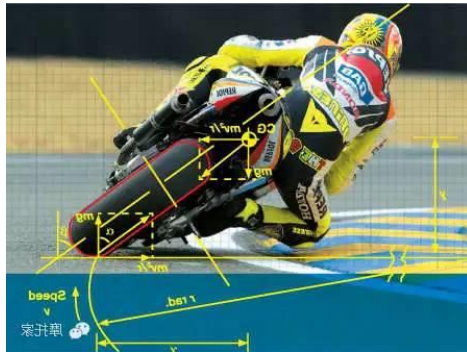

<https://images.app.goo.gl/5p7G4g19ZayMYkb28>

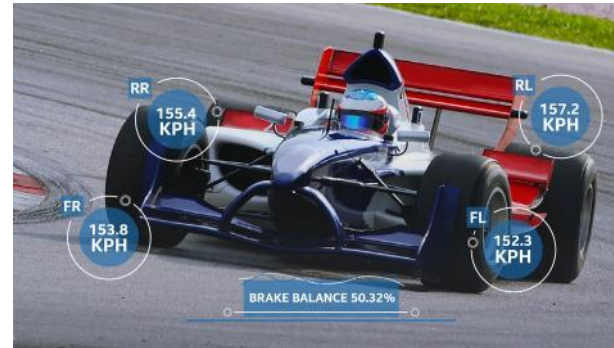

<https://images.app.goo.gl/GzScsbcFTDPsaApJ8>

● Action:

- 統整四個輪子
- 統整四個螺旋槳

● Goal:

- 方向
- 加減速

■ Middle Layer:

- For Single Agent (Single Vehicle, Car, Drone)

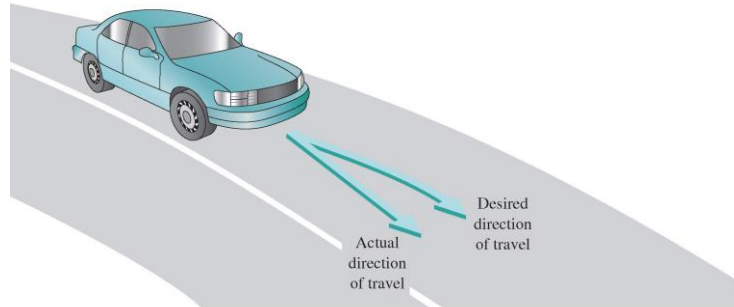

(b)

Dorf17



Franklin19

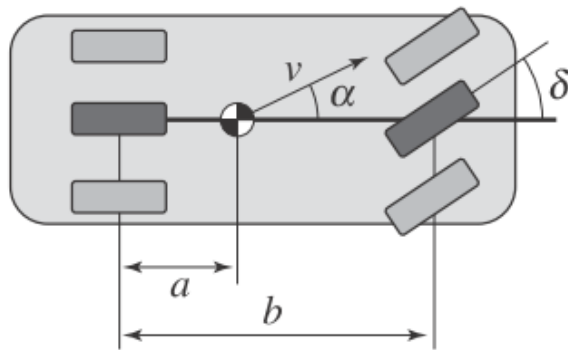

Astrom19

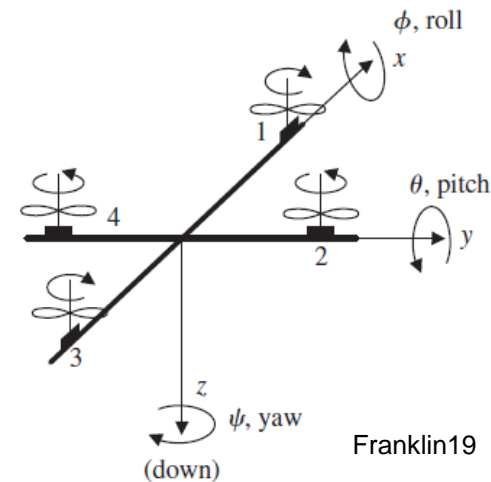

Franklin19

● Action:

- 統整四個輪子
- 統整四個螺旋槳

● Goal:

- 方向
- 加減速

Bottom Layer:

- For Subsystems (Wheel, Motor, Engine, Gear Box, Braking)

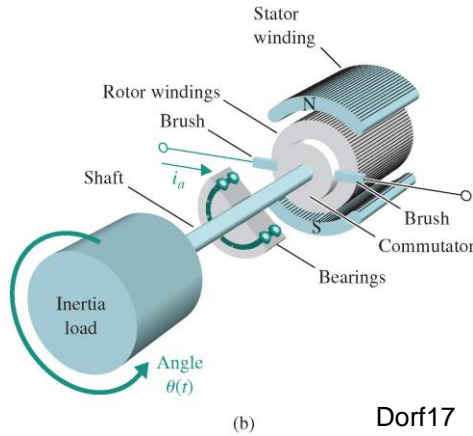
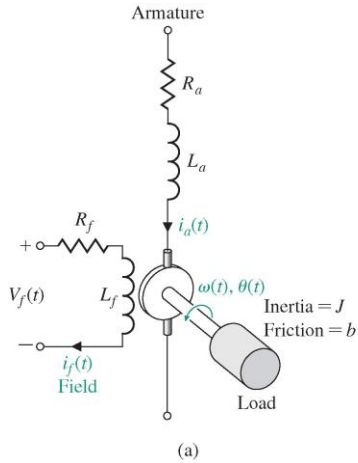

Dorf17

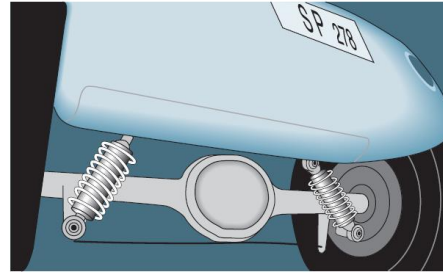

Franklin19

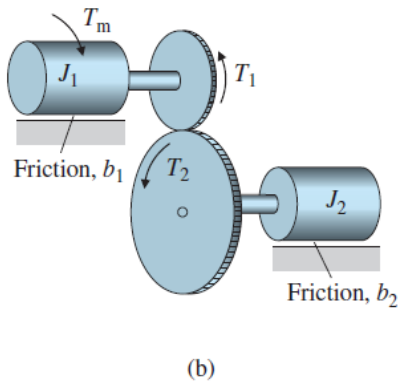

Franklin19

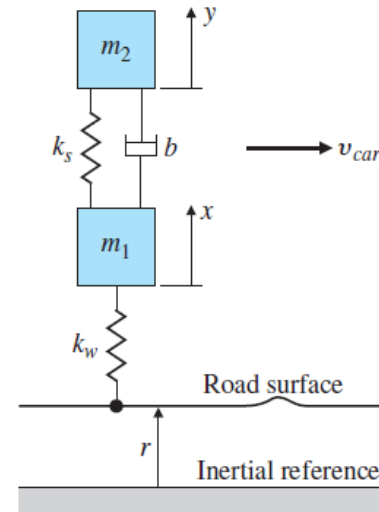

Franklin19

Action:

- 控制驅動電流/電壓

Goal:

- 每一個輪子/螺旋槳的轉速/轉角

Top Layer:

- For Multiple Agents (Group of Vehicles, Cars, Drones)

- 方向盤
- 油門煞車



- 位置/車道
- 速度/方向



Middle Layer:

- For Single Agent (Single Vehicle, Car, Drone)

- 統整四個輪子
- 統整四個螺旋槳



- 方向
- 加減速



Bottom Layer:

- For Subsystems (Wheel, Motor, Engine, Gear Box, Braking)

- 控制驅動電流/電壓

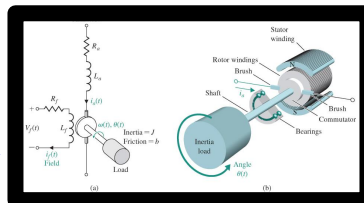

- 每一個輪子/螺旋槳的轉速/轉角



Signals & Systems

Control Systems

Plant (P)

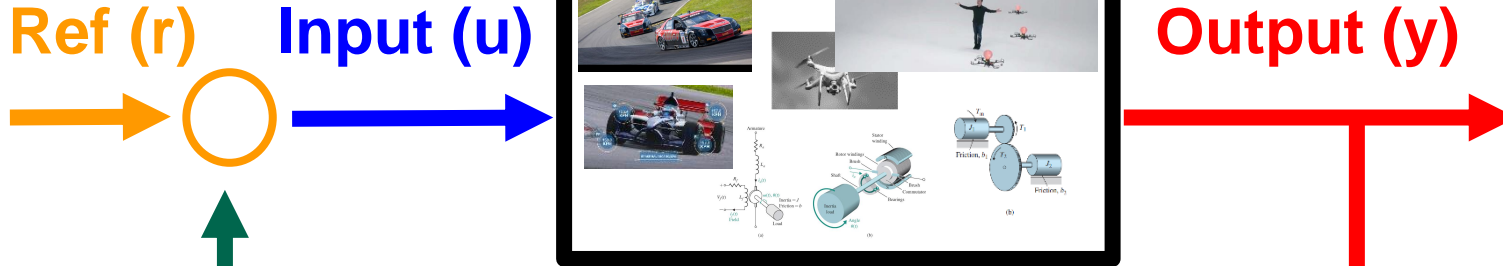

$$\frac{d^2y(t)}{dt^2} + 2 \frac{dy(t)}{dt} - 3y(t) = 5u(t)$$

$$P(s) = \frac{Y(s)}{U(s)} = \frac{5}{s^2 + 2s - 3}$$

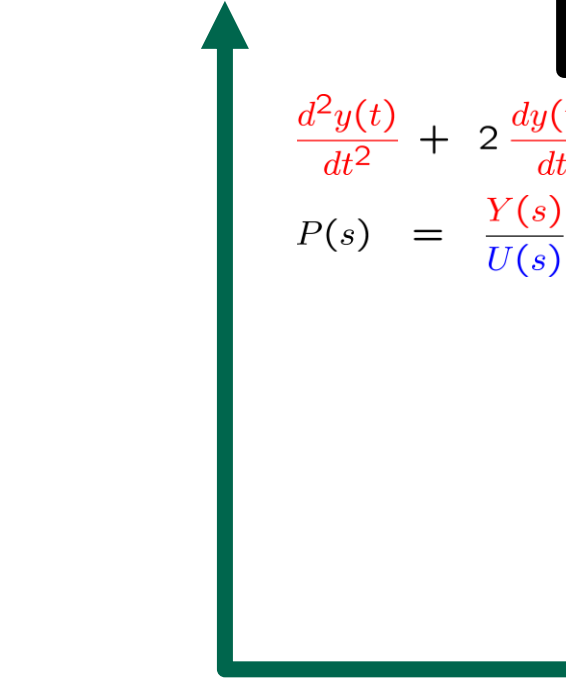
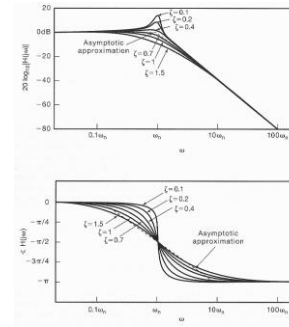
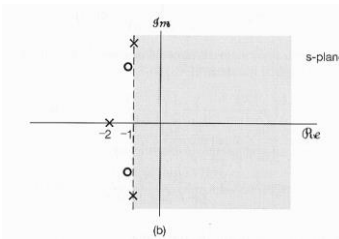

1. Model
2. Response
3. Analysis
4. Feedback
5. Control

$$\frac{d^2y(t)}{dt^2} + 4 \frac{dy(t)}{dt} + 3y(t) = 3r(t)$$

$$G(s) = \frac{Y(s)}{R(s)} = \frac{3}{s^2 + 4s + 3}$$

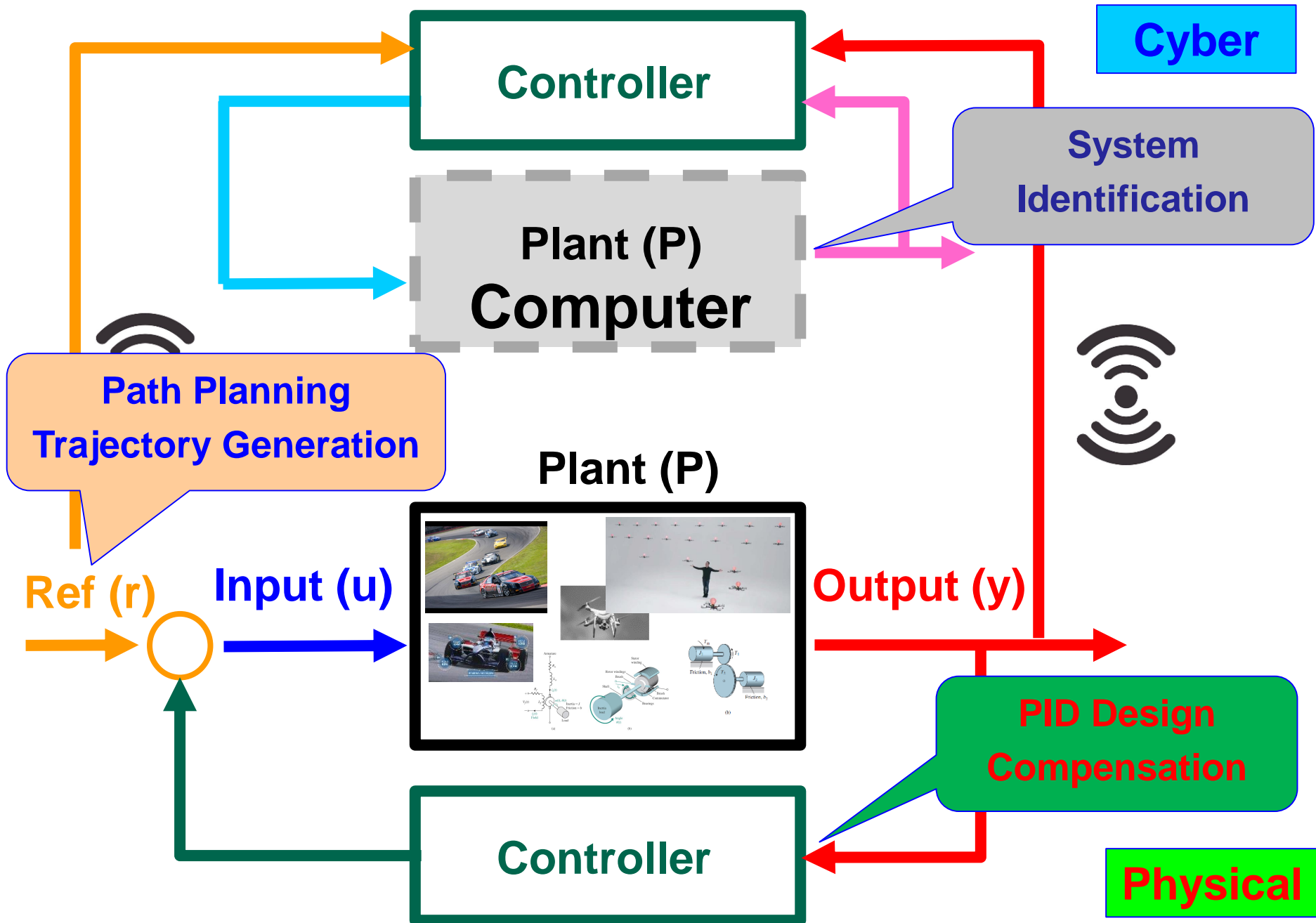



Teacher

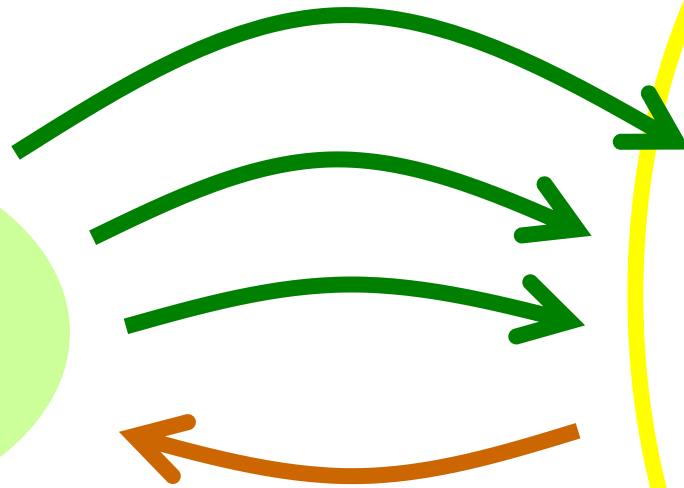

Students

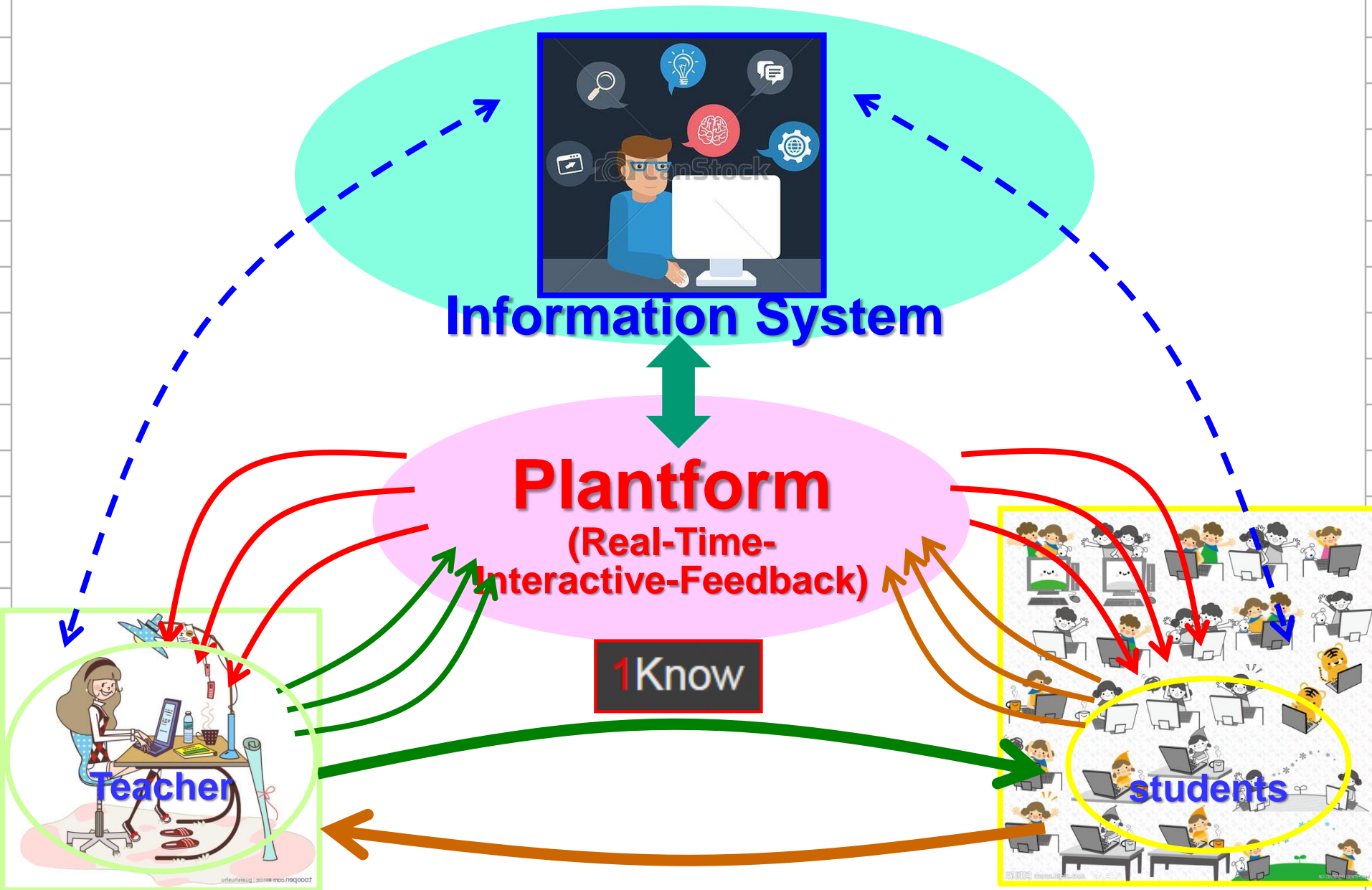

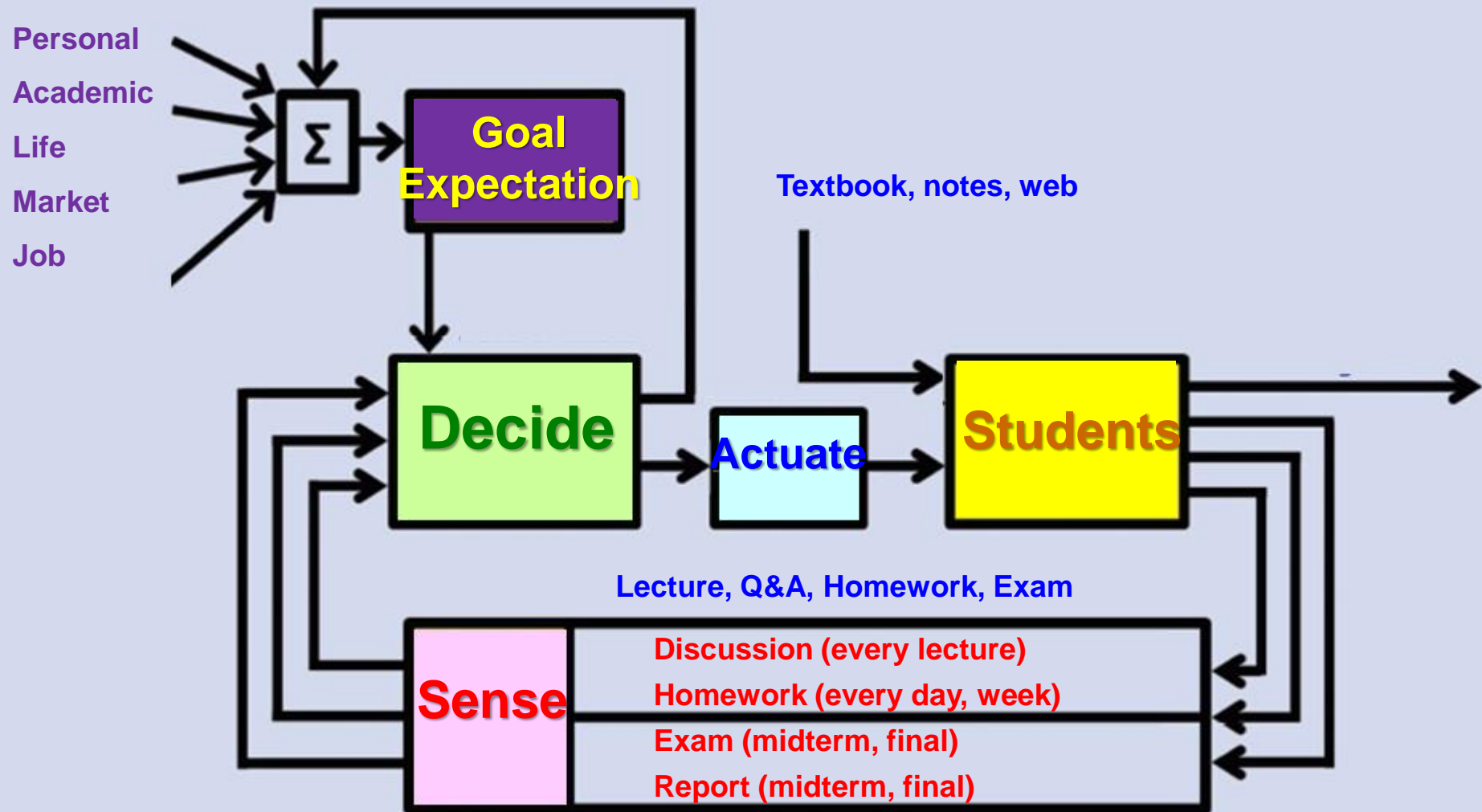

- Manual Control
- Automatic Control

- Open-Loop Control
- Closed-Loop Control or Feedback Control

- Regulation
- Tracking or Servo System

- Feedback
- Feedforward
- Control as a hidden technology

- Systems, Subsystems, Signal/Information Flow
- Process, Plant,
Actuator, Sensor, Filter, Controller, Compensator

- **Goals:**
 - Stability
 - Tracking
 - Disturbance Rejection
 - Robustness

- **Classic Control**

- **Modern Control**

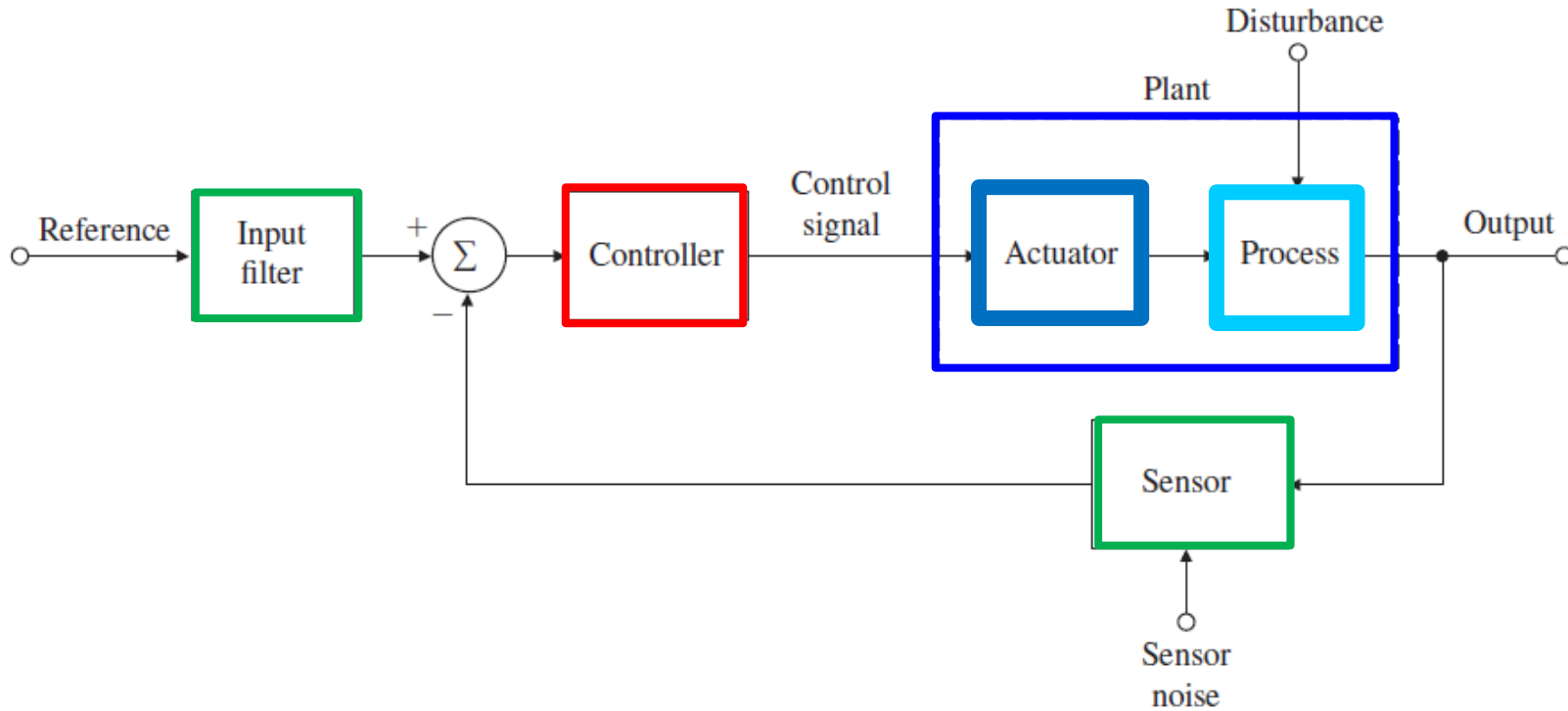

- **Modeling:** the plant
 - **Analysis:** the plant
 - **Design:** the controller
- for the plant

