

USER GUIDE

life

iBind™ Western System

For western detection of proteins on PVDF
or nitrocellulose membranes

Catalog Number SLF1000

Revision C.0

Publication Number MAN0008949

[Online Specials](#)

For Research Use Only. Not for use in diagnostic procedures.

life
technologies

For Research Use Only. Not for use in diagnostic procedures.

Information in this document is subject to change without notice.

DISCLAIMER

LIFE TECHNOLOGIES CORPORATION AND/OR ITS AFFILIATE(S) DISCLAIM ALL WARRANTIES WITH RESPECT TO THIS DOCUMENT, EXPRESSED OR IMPLIED, INCLUDING BUT NOT LIMITED TO THOSE OF MERCHANTABILITY, FITNESS FOR A PARTICULAR PURPOSE, OR NON-INFRINGEMENT. TO THE EXTENT ALLOWED BY LAW, IN NO EVENT SHALL LIFE TECHNOLOGIES AND/OR ITS AFFILIATE(S) BE LIABLE, WHETHER IN CONTRACT, TORT, WARRANTY, OR UNDER ANY STATUTE OR ON ANY OTHER BASIS FOR SPECIAL, INCIDENTAL, INDIRECT, PUNITIVE, MULTIPLE OR CONSEQUENTIAL DAMAGES IN CONNECTION WITH OR ARISING FROM THIS DOCUMENT, INCLUDING BUT NOT LIMITED TO THE USE THEREOF.

IMPORTANT LICENSING INFORMATION

These products may be covered by one or more Limited Use Label Licenses. By use of these products, you accept the terms and conditions of all applicable Limited Use Label Licenses.

TRADEMARKS

© 2014 Thermo Fisher Scientific Inc. All rights reserved. All trademarks are the property of Thermo Fisher Scientific and its subsidiaries unless otherwise specified. LI-COR, Odyssey, and IRDye are registered trademarks of LI-COR, Inc.

Contents

Product Contents	2
Introduction	3
Description of Parts	6
Methods.....	9
HRP and AP Detection Procedure	10
Fluorescent Detection Procedure	13
Using the iBind™ Western Device	16
Detection.....	19
Optimization.....	22
Maintenance.....	23
Troubleshooting	24
Appendix A	30
Product Specifications	30
Related Products.....	31
Technical Support	32

Product Contents



**iBind™
Western
Device**

The components included with the iBind™ Western System kit (Cat. no. SLF1000) are listed below.

Components	Quantity
iBind™ Western Device	1 unit
iBind™ Blotting Roller	1 roller
iBind™ Window Cover	1 unit

Introduction

Overview

The iBind™ Western System is a benchtop device utilizing sequential lateral flow (SLF) to perform hands-free blocking, antibody binding, and washes for western detection workflows.

The iBind™ Western System uses no external power source, and relies on mechanical pressure from the iBind™ Western Device on a iBind™ Card to generate the sequential flow of immunodetection reagents for performing the blocking, antibody binding, and wash steps involved in western detection workflows.

System components

The iBind™ Western System consists of:

- iBind™ Western Device
- iBind™ Cards
- iBind™ Solution Kit
- iBind™ Fluorescent Detection (FD) Solution Kit
- Novex® AP Chemiluminescent Detection Kits

iBind™ Cards

The iBind™ Card is a unique matrix optimized for homogenous flow of immunodetection reagents along its length. The iBind™ Cards are sold separately (see page 31 for ordering details).

The components included with the iBind™ Cards (Cat. no. SLF1010) are listed below.

Product	Quantity	Storage
iBind™ Card	10 cards	Room temperature

Continued on next page

Introduction, Continued

iBind™ Fluorescent Detection (FD) Solution Kit

The iBind™ Fluorescent Detection (FD) Solution Kit is used for preparing blocking, dilution, and washing buffers for the iBind™ western detection protocol in conjunction with Alexa Fluor® or IRDye® conjugated secondary antibodies. The iBind™ Fluorescent Detection (FD) Solution Kit is sold separately (see page 31 for ordering details).

The components included with the iBind™ Fluorescent Detection (FD) Solution Kit (Cat. no. SLF1019) are listed below.

Product	Quantity	Storage
iBind™ FD 5X Buffer	60 mL	4°C
iBind™ 100X Additive	2 × 1.5 mL	4°C
iBind™ FD 10% SDS	100 µL	Room temperature

iBind™ Solution Kit

The iBind™ Solution Kit is used for preparing blocking, dilution, and washing buffers for the iBind™ western detection protocol using chemiluminescent or chromogenic substrates, and alkaline phosphatase (AP) or horseradish peroxidase (HRP) conjugated secondary antibodies. The iBind™ Solution Kit is sold separately (see page 31 for ordering details).

The components included with the iBind™ Solution Kit (Cat. no. SLF1020) are listed below.

Product	Quantity	Storage
iBind™ 5X Buffer	60 mL	4°C
iBind™ 100X Additive	2 × 1.5 mL	4°C

Continued on next page

Introduction, Continued

Novex® AP Chemiluminescent Detection Kit

The Novex® AP Chemiluminescent Detection Kits are used for secondary antibody binding, and chemiluminescent detection in the iBind™ western detection protocol. Novex® AP Chemiluminescent Detection Kits are sold separately (see page 31 for ordering details).

The components included with the Novex® AP Chemiluminescent Detection Kits (Cat. nos. SLF1021, and SLF1022) are listed below.

Components	Anti-Mouse 2° (SLF1021)	Anti-Rabbit 2° (SLF1022)	Storage
Anti-Mouse Secondary Antibody Alk-Phosphatase	100 µL	—	4°C
Anti-Rabbit Secondary Antibody Alk-Phosphatase	—	100 µL	4°C
Novex® AP Chemiluminescent Substrate (CDP-Star®)	25 mL	25 mL	4°C
Chemiluminescent Substrate Enhancer (Nitro-Block-II™)	2.5 mL	2.5 mL	4°C

Description of Parts

iBind™ Western Device

The iBind™ Western Device consists of a metallic surface made up of three stages and a lid with four wells for loading blocking solution, antibodies, and wash solutions.

The Hinge Stage and Latch Stage are spring plates designed to apply specific amounts of pressure on an iBind™ Card placed on the three stages, when the lid of the device is locked.

The pressure on the iBind™ Card results in the sequential flow of immunodetection reagents from the wells in which they are loaded. The flow rate is highly reproducible because the amount of pressure and the viscosity of the fluids remain constant.

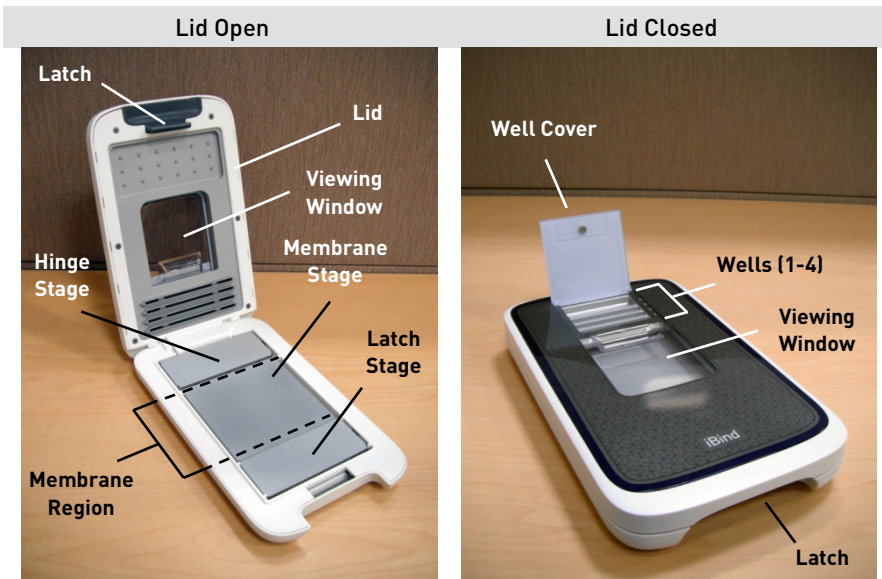

Continued on next page

Description of Parts, Continued

iBind™ Card

The iBind™ Card consists of a Flow Region and a Stack. The card is a unique matrix optimized for homogenous flow of immunodetection reagents along the Flow Region.

Important: Do not bend the iBind™ Card.

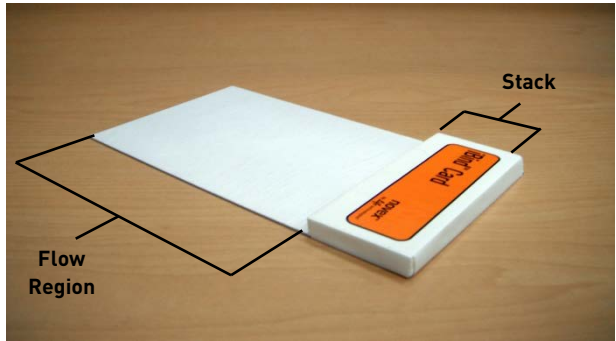

The iBind™ Card is placed on the iBind™ Western Device so that it is aligned with the stoppers and alignment tabs.

Note: make sure that the lid is completely open to expose the stoppers near the hinge.

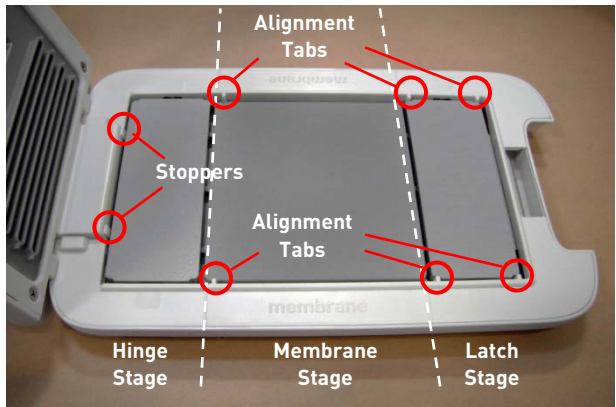

Continued on next page

Description of Parts, Continued

iBind™ Window Cover

The iBind™ Window Cover is an opaque rubber cover placed over the viewing window when using light sensitive reagents to perform western detection.



Blotting Roller

The Blotting Roller is a plastic roller attached to a stainless steel handle (8.6 cm wide). The Blotting Roller is used to remove any air bubbles between the membrane and the iBind™ Card.

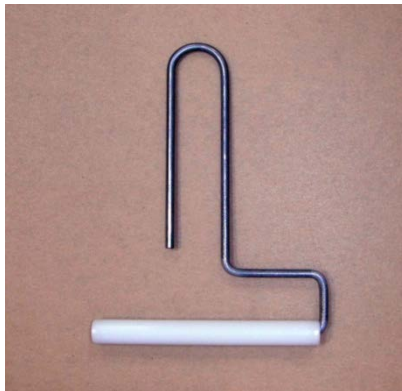

Methods

General guidelines

- Wear the proper protective equipment (gloves, laboratory coat, eye protection) when performing experiments.
- If you mark your membrane with ink, mark the membrane near the low molecular weight region.
- **Caution:** Exercise care when closing the lid of the iBind™ Western Device to avoid catching fingers.
- **Important:** No part of the membrane should be directly under the wells when the lid is closed.
- Do not move the iBind™ Western Device or open the lid until Well 4 is completely empty (2.5 hours or longer).
Note: The membrane can be left in the iBind™ Western Device overnight if desired.
- 1X iBind™ Solution is used for HRP and AP detection, while iBind™ FD Solution is used for fluorescent detection.

When performing the fluorescent detection procedure:

- Protect western detection reagents from light after adding them to the wells by placing the iBind™ Window Cover over the viewing window, and closing the well cover.

Continued on next page

HRP and AP Detection Procedure

Experimental overview Use the following protocol when using the iBind™ Western System in conjunction with HRP or AP detection protocols.

Step	Action	Page
1	Prepare 1X iBind™ Solution	10
2	Prepare membrane	11
3	Prepare diluted antibody solutions	12
4	Prepare iBind™ Card	16–17
5	Add solutions to iBind™ Wells and incubate 2–3 hours	18
6	Perform detection	19–20

Prepare 1X iBind™ Solution

1X iBind™ Solution is used for blocking, diluting antibodies, washing, and wetting the iBind™ Card. Prepare 30 mL of 1X iBind™ Solution for each run as follows:

Reagent	Volume
iBind™ 5X Buffer	6 mL
iBind™ 100X Additive	300 µL
Distilled Water	23.7 mL
Total	30 mL

Continued on next page

HRP and AP Detection, Continued

Prepare membrane

Membranes should only be blocked with 1X iBind™ Solution. Store membranes in 1X iBind™ Solution, in distilled water, or dry.

Before performing the antibody binding, prepare the membrane as follows:

- Trim the membrane to 9 cm × 9 cm.
- Pre-activate PVDF membranes in 100% methanol, and rinse in distilled water.
- Immerse the blotted membrane (protein-side up) in 5 mL of 1X iBind™ Solution.

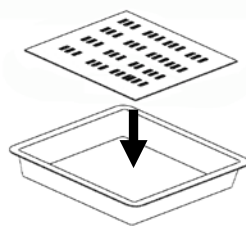

Continued on next page

HRP and AP Detection, Continued

Prepare primary antibody solution

Dilute primary antibodies with 1X iBind™ Solution according to the enzyme system being used for detection. 2 mL of each antibody solution are required for each run.

Component	HRP Detection
1X iBind™ Solution	2 mL
Primary Antibody	Add primary antibody so that the final concentration is equal to the manufacturer's recommended dilution.
Component	AP Detection (Novex® AP Detection Kit only)
1X iBind™ Solution	2 mL
Primary Antibody	Add primary antibody so that the final concentration is equal to the manufacturer's recommended dilution.

Prepare secondary antibody solution

Dilute secondary antibodies with 1X iBind™ Solution according to the enzyme system and primary antibody being used for detection. 2 mL of each antibody solution are required for each run.

Component	HRP Detection
1X iBind™ Solution	2 mL
Secondary Antibody	Add secondary antibody so that the final concentration is 5X the manufacturer's recommended dilution (e.g. prepare a 1:1000 dilution if a 1:5000 dilution is normally recommended).
Component	AP Detection (Novex® AP Detection Kit only)
1X iBind™ Solution	2 mL
<ul style="list-style-type: none"> • Anti-Mouse 2° Antibody OR ○ Anti-Rabbit 2° Antibody 	<ul style="list-style-type: none"> • 2 µL (1:1000 dilution) ○ 1 µL (1:2000 dilution)

Continued on next page

Fluorescent Detection Procedure

Experimental overview Use the following protocol when using the iBind™ Western System in conjunction with the LI-COR® Odyssey® Imaging System.

Step	Action	Page
1	Prepare 1X iBind™ FD Solution	13
2	Prepare membrane	14
3	Prepare diluted antibody solutions	15
4	Prepare iBind™ Card	16–17
5	Add solutions to iBind™ Wells and incubate 2–3 hours	18
6	Perform detection	21

Prepare 1X iBind™ FD Solution

1X iBind™ FD Solution is used for blocking, diluting antibodies, washing, and wetting the iBind™ Card.

- The Standard 1X iBind™ FD Solution is recommended for use with most primary antibodies.
- Use the Optional 1X iBind™ FD Solution only if initial results give low sensitivity or high background.

Prepare 30 mL of 1X iBind™ FD Solution for each run as follows:

Reagent	Volume	
	Standard	Optional
iBind™ FD 5X Buffer	6 mL	1.5 mL
iBind™ 100X Additive	75 µL	300 µL
Distilled Water	23.9 mL	28.2 mL
Total	30 mL	30 mL

Continued on next page

Fluorescent Detection, Continued

Prepare membrane

Membranes should only be blocked with 1X iBind™ FD Solution. Store membranes in 1X iBind™ FD Solution, in distilled water, or dry.

Before performing the antibody binding, prepare the membrane as follows:

- Trim the membrane to 9 cm × 9 cm.
- Pre-activate PVDF membranes in 100% methanol, and rinse in distilled water.
- Immerse the blotted membrane (protein-side up) in 5 mL of 1X iBind™ FD Solution.

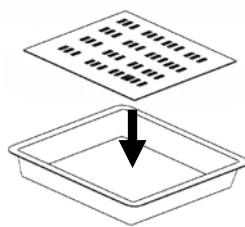

Continued on next page

Fluorescent Detection, Continued

Prepare primary antibody solution

Dilute antibodies with 1X iBind™ FD Solution. 2 mL of each antibody solution are required for each run.

Component	Volume
1X iBind™ FD Solution	2 mL
Primary Antibody	Add primary antibody so that the final concentration is equal to the manufacturer's recommended dilution.

Prepare secondary antibody solutions

Dilute antibodies with 1X iBind™ FD Solution. 2 mL of each antibody solution are required for each run.

SDS is added to a final concentration of 0.05% to reduce background signal, particularly when using PVDF membranes, or IRDye® 680LT secondary antibodies.

Component	Volume
1X iBind™ FD Solution	2 mL
iBind™ FD 10% SDS	10 µL
<ul style="list-style-type: none">• Alexa Fluor® 680 OR○ IRDye® 680LT	<ul style="list-style-type: none">• 1 µL (1:2000 dilution)○ 0.5 µL (1:4000 dilution)
<ul style="list-style-type: none">• AlexaFluor® 790 OR○ IRDye® 800CW	<ul style="list-style-type: none">• 1 µL (1:2000 dilution)○ 0.67 µL (1:3000 dilution)

Continued on next page

Using the iBind™ Western Device

Prepare iBind™ Card

1. Open the lid of the iBind™ Western Device.
2. Open the packaging for the iBind™ Card.
3. Hold the iBind™ Card by the Stack, and remove the card from the packaging.
4. Place the iBind™ Card on the Stage and align it with the stoppers (see page 7 for details).
5. Pipette 5 mL of 1X iBind™ / iBind™ FD Solution evenly across the Flow Region.

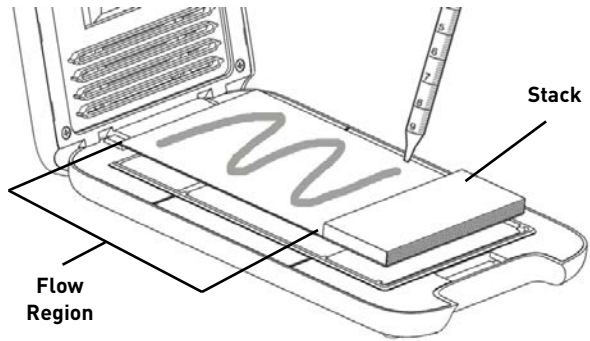

6. Pipette 1 mL of 1X iBind™ / iBind™ FD Solution so that it pools at the center of the membrane region on the iBind™ Card.

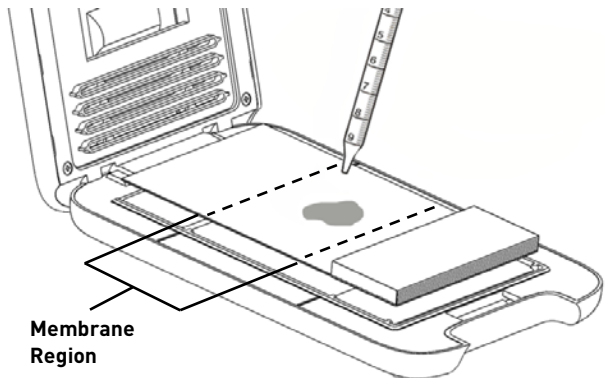

Continued on next page

Protocol, Continued

Perform antibody binding

1. Place the membrane on top of the pooled solution with the **protein-side down**, and the low molecular weight protein region closest to the Stack. **Note:** the membrane should not come in contact with the stack.

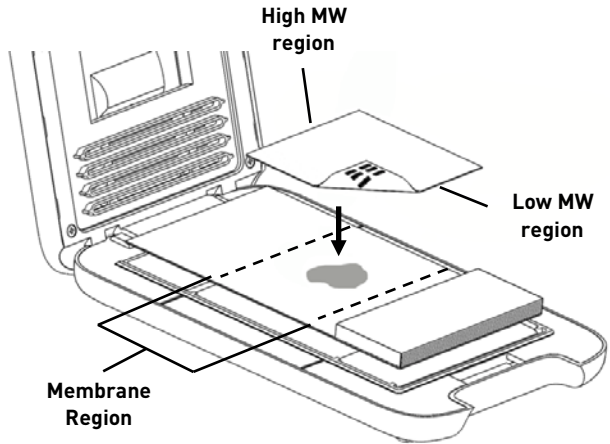

2. Use the blotting roller to remove any air bubbles between the membrane and the iBind™ Card.

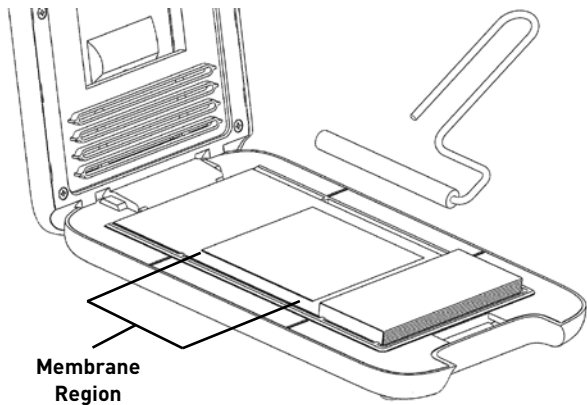

Continued on next page

Protocol, Continued

Perform antibody binding, continued

3. Make sure that the iBind™ Card is aligned against the stoppers, and that the membrane is within the boundaries of the membrane region. **No part of the membrane should be directly under the wells.**
4. Close the lid of the device. A clicking sound indicates the lid is properly locked.
5. Open the Well Cover and add solutions sequentially to the iBind™ Wells starting with Well 1:

Well	Solution
1	2 mL diluted primary antibody
2	2 mL of 1X iBind™/ iBind™ FD Solution
3	2 mL diluted secondary antibody
4	6 mL of 1X iBind™/ iBind™ FD Solution

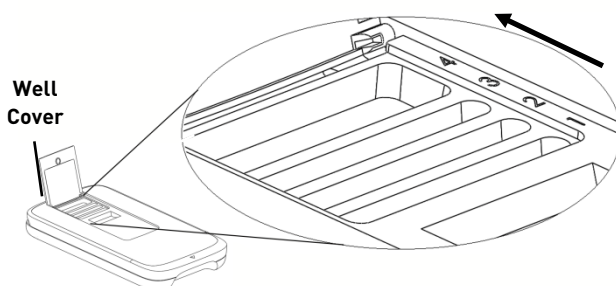

6. Place the iBind™ Window Cover over the viewing window.
 7. Close the Well Cover and incubate 2.5 hours or longer.
Note: The membrane can be left in the iBind™ Western Device overnight, but perform detection as soon as possible to avoid loss of sensitivity.
 8. Open the Well Cover to verify that Well 4 is completely empty (indicating that the run is over) before opening the lid.
 9. After incubation, rinse the membrane twice in 20 mL of distilled water for 2 minutes, and proceed to the appropriate detection protocol (page 19–21).
-

Detection

Chemiluminescent detection with alkaline-phosphatase

The following protocol describes performing chemiluminescent detection on a membrane using the Novex® AP Chemiluminescent Detection Kit after blocking, antibody binding, and washes have been completed by the iBind™ Western Device.

1. Prepare chemiluminescent substrate solution based on the type of membrane being used.

Item	Nitrocellulose	PVDF
Novex® AP Chemiluminescent Substrate (CDP-Star®)	2.375 mL	2.5 mL
Chemiluminescent Substrate Enhancer (Nitro-Block-II™)	0.125 mL	—

2. Place the membrane on a sheet of transparency plastic with the **protein-side up**. Do not allow the membrane to dry out.
 3. With a clean pipette, apply 2.5 mL of the chemiluminescent substrate solution evenly across the membrane surface (do not touch the membrane surface with the pipette).
 4. Incubate for 5 minutes.
 5. Blot excess chemiluminescent substrate solution from the membrane surface with filter paper. Do not allow the membrane to dry out.
 6. Cover the membrane with another clean piece of transparency plastic, or plastic wrap.
 7. Place a piece of X-ray film over the membrane sandwich and expose for 1 second to several minutes, then develop the X-ray film,
OR
Scan the membrane sandwich in a digital imager.
-

Continued on next page

Detection, Continued

Chemi-luminescent detection with horse-radish peroxidase

The following protocol describes performing chemiluminescent detection on a membrane using the Novex® ECL Chemiluminescent Substrate Reagent Kit after blocking, antibody binding, and washes have been completed by the iBind™ Western Device.

Light emission is most intense from 5–30 minutes after membrane incubation and decreases slowly with time over the course of several hours.

1. Prepare chemiluminescent substrate solution.

Item	Volume
HRP Chemiluminescent Substrate, Reagent A	1.25 mL
HRP Chemiluminescent Substrate, Reagent B	1.25 mL

2. Place the membrane on a sheet of transparency plastic with the **protein-side up**. Do not allow the membrane to dry out.
3. With a clean pipette, apply 2.5 mL of the chemiluminescent substrate solution evenly across the membrane surface (do not touch the membrane surface with the pipette).
4. Incubate for 1 minute.
5. Blot excess chemiluminescent substrate solution from the membrane surface with filter paper. Do not allow the membrane to dry out.
6. Cover the membrane with another clean piece of transparency plastic, or plastic wrap.
7. Place a piece of X-ray film over the membrane sandwich and expose for 1 second to several minutes, then develop the X-ray film,

OR

Scan the membrane sandwich in a digital imager.

Continued on next page

Detection, Continued

Fluorescent detection

The following protocol describes performing fluorescent detection on a membrane after blocking, antibody binding, and washes have been completed by the iBind™ Western Device.

1. Rinse the membrane with water after completion of the run.
 2. Scan the membrane (wet or dry) with the LI-COR® Odyssey® CLx imager using the appropriate channel on “Auto” resolution.
-

Optimization

Chemi-luminescent detection

After performing an initial experiment, conditions can be optimized by varying the dilution of primary and secondary antibodies according to the following table:

Condition/Observation	Primary and Secondary Antibody Concentrations (HRP Protocol)	
	Primary	Secondary
Low signal	1X-5X*	5X
High background with strong signal	1X	1X-5X**

Condition/Observation	Secondary Antibody Concentration (Novex® AP Chemiluminescent Detection Kit)	
	Anti-rabbit	Anti-mouse
Low signal	1:1000 to 1:500	1:500 to 1:250
High background with strong signal	≥ 1:4000	≥ 1:2000

* Start with a 1X concentration of primary antibody. Further optimization by increasing the primary antibody concentration may be necessary depending upon your results.

** Start with a 5X concentration of secondary antibody. Further optimization by decreasing the secondary antibody concentration may be necessary depending upon your results.

Fluorescent detection

The Standard 1X iBind™ FD Solution is recommended for use with most primary antibodies, and should be used for all initial experiments.

- If initial results give low sensitivity, switch from the Standard 1X iBind™ FD Solution to the Optional 1X iBind™ FD Solution (page 13).
 - If low sensitivity persists, increase the primary antibody concentration from 1X-5X as needed.
-

Maintenance

General guidelines

- Rinse the iBind™ Western Device under running water after each use and allow the device to dry before additional usage.
- To maximize the life of the springs in iBind™ Western Device, store the device with latch unlocked, and the lid open as shown below:



Troubleshooting

Problem	Cause	Solution
High background	Membrane not completely wet	Follow instructions for pre-wetting the membrane. Use an incubation dish which is small enough to allow thorough coverage of membrane to prevent drying out.
	Membrane is contaminated	Use only clean, new membranes. Wear clean gloves at all times and use forceps when handling membranes.
	Film overexposed or became wet during exposure	Decrease exposure time or allow signal to further decay. Prevent leakage by encasing membrane in transparency film and blotting excess substrate from edges before exposure.
	Solutions or incubation tray is contaminated	Use clean glassware and purified water to prepare solutions. Replace or clean the tray thoroughly with a glassware-cleaning detergent. Rinse thoroughly with purified water. Wear clean gloves at all times.
	Concentrated primary antibody used	Follow the supplier's recommended dilution or determine the optimum concentration by dot blotting.
	Incorrect chemiluminescent substrate used for PVDF	Make sure CDP-Star without enhancer is used.
	Blot is overdeveloped	Follow recommended developing time or remove blot from substrate when signal-to-noise ratio is acceptable.
	Ink used to label membrane	Any labeling of the membrane with ink should be limited to the low MW region of the blot.

Continued on next page

Troubleshooting, Continued

Problem	Cause	Solution
High background, continued	Improper preparation of iBind™ / iBind™ FD Solution	Prepare 1X iBind™ / iBind™ FD Solutions as directed (pages 10, 13).
	Improper application of solutions to iBind™ Wells	Add the appropriate solutions for each well in numerical order (page 18).
	Blot improperly placed on iBind™ Card	<ul style="list-style-type: none"> Place the membrane in the designated Membrane Region on the iBind™ Card. The protein side of the blot should be in contact with the iBind™ Card. The low MW regions should be closest to the Stack. The membrane should not be in contact with the Stack.
	Card stack wet prior to run	Ensure that 5 mL of 1X iBind™ / iBind™ FD Solution is added to the flow region of the card. Avoid adding the solution to the Stack.
Non-specific binding	Membrane contaminated by fingerprints or keratin proteins	Wear clean gloves at all times and use forceps when handling membranes. Always handle membranes around the edges.
	Primary antibody too concentrated	Follow the supplier's recommended dilution or determine the optimum concentration by dot blotting.
	Insufficient removal of SDS/weakly bound proteins from membrane after blotting	Follow instructions for membrane preparation before immunodetection (pages 11, 14).
	Affinity of the primary antibody for the protein standards	Check with protein standard manufacturer for homologies with primary antibody.
	Improper preparation of iBind™ / iBind™ FD Solution	Prepare 1X iBind™ / iBind™ FD Solutions as directed (pages 10, 13).

Continued on next page

Troubleshooting, Continued

Problem	Cause	Solution
Weak or no signal	Poor or incomplete transfer	Refer to Western Blotting instructions (IM-9051) and repeat blot. After blotting, stain membrane to measure transfer efficiency. Use positive control and/or molecular weight marker.
	Membrane not completely wet	Follow instructions for pre-wetting the membrane.
	Primary antibody concentration too low	Follow the supplier's recommended dilution or determine the optimum concentration by dot blotting.
	Inactive primary antibody	Determine activity by performing a dot-blot.
	Low Affinity of primary antibody to antigen	Obtain a higher affinity primary antibody.
	Contaminated secondary antibody solution	Wear gloves at all times and keep bottles tightly capped when not in use. Use only purified water when preparing reagents.
	Protein of interest ran off the gel	Match gel separation range to size of protein being transferred.
	Poor retention of proteins	Match gel separation range to size of protein being transferred. Use a molecular weight marker with relevant size proteins. Larger proteins require more transfer time, smaller proteins less. Use membrane with the appropriate binding capacity (see Western Blotting instructions).
	Improper preparation of iBind™ / iBind™ FD Solution	Prepare 1X iBind™ / iBind™ FD Solutions as directed (pages 10, 13).

Continued on next page

Troubleshooting, Continued

Problem	Cause	Solution
Weak or no signal, continued	Improper application of solutions to iBind™ Wells	Ensure that the solutions are added to the correct wells and that the wells are loaded in numerical order.
	Blot improperly placed on iBind™ Card	Ensure that the protein side of the blot is in contact with the iBind™ Card and is placed in the region labeled “membrane”.
	Stack wet prior to run	Ensure that 5 mL of 1X iBind™ / iBind™ FD Solution is added to the flat region of the iBind™ Card. Avoid adding solution to the Stack.
	Cross-contamination of solutions in wells	Do not move the iBind™ Western Device during the run.
	iBind™ Card damaged	Replace with new card. Ensure that rolling of the membrane on the card is limited to the area labeled “membrane”.
	Membrane is not in proper contact with the iBind™ Card	Place the membrane on the iBind™ Card immediately after adding a 1 mL pool of 1X iBind™ / iBind™ FD Solution. Use the roller provided to ensure proper contact.
	Device opened prior to completion of run	The device should not be opened once the card has been placed in the device. Re-sealing of the wells on the card can result in leaks.
	Sample improperly prepared; antigenicity weakened or destroyed	SDS and reducing agents may interfere with some antibody/antigen affinities.
	Sample too dilute	Load a higher concentration or amount of protein onto the gel.
Protein weakly bound to membrane	Ensure that transfer buffer contains 10–20% methanol.	

Continued on next page

Troubleshooting, Continued

Problem	Cause	Solution
Weak or no signal, continued	Insufficient exposure time	Re-expose film for a longer period of time.
	Insufficient substrate incubation	Perform each step for the specified amount of time or remove blot from substrate when signal-to-noise ratio is acceptable.
	Substrate is contaminated	Wear gloves at all times and keep bottles tightly capped when not in use.
	Blots are too old	Protein may have broken down over time. Use freshly prepared blots.
Large, scattered signal	Protein is overloaded	Reduce load or dilute concentration of sample.
	Poor or incomplete transfer	Refer to Western Blotting instructions (IM-9051) and repeat blot.
	Primary antibody is too concentrated	Follow the supplier's recommended dilution or determine the optimum concentration by dot blotting.
Run Times in Excess of 3 hours	iBind™ Card damaged	Replace with new card. Ensure that rolling of the membrane on the card is limited to the area labeled "membrane".
	Stack wet prior to run	Ensure that 5 mL of 1X iBind™ / iBind™ FD Solution is added to the flat region of the iBind™ Card. Avoid adding solution to the Stack.
	Improper preparation of iBind™ / iBind™ FD Solution	Prepare 1X iBind™ / iBind™ FD Solutions as directed (pages 10, 13).

Continued on next page

Troubleshooting, Continued

Problem	Cause	Solution
"Spotted" membrane	Poor or incomplete transfer	Refer to Western Blotting instructions (IM-9051) and repeat blot.
	Membrane pads are dirty or contaminated	Soak with detergent and rinse thoroughly with purified water before use. Replace pads when they become worn or discolored.
	Membrane not completely wet	Follow instructions for pre-wetting the membrane.
	Membrane is contaminated by fingerprints or keratin proteins	Wear clean gloves at all times and use forceps when handling membranes. Always handle membranes around the edges.
	Uneven blocking	The incubation dish must be small enough to allow thorough coverage of membrane.
	Ink used to label membrane	Any labeling of the membrane with ink should be limited to the low MW region of the blot.
	iBind™ Card damaged	Replace with new card. Ensure that rolling of the membrane on the card is limited to membrane region.
	Membrane is not in proper contact with the iBind™ Card	Place the membrane on the iBind™ Card immediately after adding a 1 mL pool of 1X iBind™ / iBind™ FD Solution. Use the roller provided to ensure proper contact.

Appendix A

Product Specifications

iBind™ Western Device specifications

Dimensions:	24.2 cm (l) × 14.6 cm (w) × 3.5 cm (h)
Material:	Aluminum, plastic (PC/ABS), steel, silicone, neodymium (magnets)
Operating Temperature:	18°C to 30°C
Temperature Limit:	30°C

The iBind™ Western Device is impervious to alcohol, but not compatible with chlorinated hydrocarbons (e.g., chloroform), aromatic hydrocarbons (e.g., toluene, benzene) or acetone.

iBind™ Western Card specifications

Dimensions:	17.8 cm (l) × 10 cm (w) × 0.8 cm (stack height)
Material:	Glass fiber
Operating Temperature:	18°C to 30°C
Temperature Limit:	30°C

Related Products

Additional products

Many of the components of the iBind™ Western System, as well as additional reagents that may be used for electrophoresis of proteins are available separately from Life Technologies. Ordering information is provided below. For details, visit www.lifetechnologies.com or call Technical Support (page 32).

Parts	Quantity	Cat. no.
iBind™ Western Device	1 device	SLF1000
iBind™ Cards	10 cards	SLF1010
iBind™ Fluorescent Detection (FD) Solution Kit	1 kit	SLF1019
iBind™ Solution Kit	1 kit	SLF1020
iBind™ Window Cover	1 unit	SLF1001
Blotting Roller	1 unit	LC2100
AlexaFluor® 680 Goat Anti-Rabbit IgG (H+L)	0.5 mL	A21109
AlexaFluor® 790 Goat Anti-Mouse IgG (H+L)	0.5 mL	A11375
Novex® AP Mouse Chemiluminescent Detection Kit	1 kit	SLF1021
Novex® AP Rabbit Chemiluminescent Detection Kit	1 kit	SLF1022
Goat Anti-Mouse IgG (H+L) - HRP	1 mL	62-6520
Goat Anti-Rabbit IgG - HRP	1 mL	65-6120
Novex® ECL Chemiluminescent Substrate Reagent Kit	2 × 125 mL	WP20005
iBlot® 2 Gel Transfer Device	1 device	IB21001
iBlot® 2 Regular Transfer Stack, Nitrocellulose	10 stacks	IB23001
iBlot® 2 Regular Transfer Stack, PVDF	10 stacks	IB24001
iBlot® 2 Mini Transfer Stack, Nitrocellulose	10 stacks	IB23002
iBlot® 2 Mini Transfer Stack, PVDF	10 stacks	IB24002
Mini Gel Tank	1 unit	A25977
Bolt® 4-12% Bis-Tris Plus Gel, 10 Well	10 gels	BG04120BOX
NuPAGE® Novex® 4-12% Bis-Tris Gels, 1.0 mm, 10 well	10 gels	NP0321BOX
NuPAGE® Novex® 4-12% Bis-Tris Gels, 1.5 mm, 10 well	10 gels	NP0335BOX

Continued on next page

Technical Support

Obtaining support

For the latest services and support information for all locations, go to www.lifetechnologies.com

At the website, you can:

- Access worldwide telephone and fax numbers to contact Technical Support and Sales facilities
 - Search through frequently asked questions (FAQs)
 - Submit a question directly to Technical Support (techsupport@lifetech.com)
 - Search for user documents, SDSs, vector maps and sequences, application notes, formulations, handbooks, certificates of analysis, citations, and other product support documents
 - Obtain information about customer training
 - Download software updates and patches
-

Safety Data Sheets (SDS)

Safety Data Sheets (SDSs) are available at www.lifetechnologies.com/support.

Certificate of Analysis

The Certificate of Analysis provides detailed quality control and product qualification information for each product. Certificates of Analysis are available on our website. Go to www.lifetechnologies.com/support and search for the Certificate of Analysis by product lot number, which is printed on the box.

Limited warranty

Life Technologies and/or its affiliate(s) warrant their products as set forth in the Life Technologies General Terms and Conditions of Sale found on the Life Technologies web site at <http://www.lifetechnologies.com/termsandconditions>. If you have any questions, please contact Life Technologies.

For support visit

www.lifetechnologies.com/support or email techsupport@lifetech.com

www.lifetechnologies.com

22 October 2014

