

FirstChoice® RLM-RACE Kit

Part Number AM1700



FirstChoice[®] RLM-RACE Kit

(Part Number AM1700)

Protocol

I.	Introduction	1
	A. Background	
	B. RLM-RACE Procedure Overview	
	C. Input RNA Requirements	
	D. Materials Provided with the Kit and Storage Conditions	
	E. Materials Not Provided with the Kit	
	F. Related Products Available from Ambion	
II.	Input RNA and PCR Primer Design	7
	A. RNA Quality	
	B. Critical Details in the Procedure	
	C. General PCR Primer Design Suggestions	
	D. Primer Design for 5' RLM-RACE	
	E. Primer Design for 3' RACE	
	F. Cloning RACE products	
III.	5' RLM-RACE Protocol	10
	A. RNA Processing	
	B. Reverse Transcription	
	C. Nested PCR for 5' RLM-RACE	
	D. Gel Analysis of Products and Expected Results	
IV.	3' RLM-RACE Protocol	15
	A. Reverse Transcription	
	B. PCR for 3' RLM-RACE	
	C. Gel Analysis of Products and Expected Results	
V.	Cloning and Sequence Analysis of Products	18
	A. Cloning	
	B. Sequence Analysis	
VI.	Troubleshooting	20
	A. Using the Positive Controls	
	B. Optimization of RLM-RACE	

VII. Appendix 26
A. References
B. Quality Control
C. Safety Information

P/N 1700M Revision D

Revision Date: August 20, 2010

For research use only. Not for use in diagnostic procedures.

Information in this document is subject to change without notice. Applied Biosystems assumes no responsibility for any errors that may appear in this document.

Applied Biosystems disclaims all warranties with respect to this document, expressed or implied, including but not limited to those of merchantability or fitness for a particular purpose. In no event shall Applied Biosystems be liable, whether in contract, tort, warranty, or under any statute or on any other basis for special, incidental, indirect, punitive, multiple or consequential damages in connection with or arising from this document, including but not limited to the use thereof.

Literature Citation: When describing a procedure for publication using this product, please refer to it as the FirstChoice[®] RLM-RACE Kit.

Warranty and Liability: Applied Biosystems is committed to delivering superior product quality and performance, supported by industry-leading global service and technical support teams. Warranty information for the accompanying consumable product is available at www.ambion.com/info/warranty in “Limited Warranty for Consumables,” which is subject to the exclusions, conditions, exceptions, and limitations set forth under the caption “EXCLUSIONS, CONDITIONS, EXCEPTIONS, AND LIMITATIONS” in the full warranty statement. Please contact Applied Biosystems if you have any questions about our warranties or would like information about post-warranty support.

Trademarks: Applied Biosystems, AB (Design), Ambion, FirstChoice and RNAqueous are registered trademarks, and ArrayScript, MagMAX and RiboPure are trademarks of Applied Biosystems Corporation or its subsidiaries in the US and/or certain other countries. SuperTaq is a trademark of Enzyme Technologies, Ltd. All other trademarks are the sole property of their respective owners.

© 2008, 2010 Ambion, Inc. All Rights Reserved.

I. Introduction

A. Background

Rapid amplification of cDNA ends (RACE) is a polymerase chain reaction-based technique which facilitates the cloning of full-length cDNA sequences when only a partial cDNA sequence is available. Traditionally, cDNA sequence is obtained from clones isolated from plasmid or phage libraries. Frequently these clones lack sequences corresponding to the 5' ends of the mRNA transcripts. The missing sequence information is typically sought by repeatedly screening the cDNA library in an effort to obtain clones that extended further towards the 5' end of the message. The nature of the enzymatic reactions employed to produce cDNA libraries limits the probability of retrieving extreme 5' sequence even from libraries that are very high quality.

Classic 5' RACE

Classic 5' RACE protocols vary slightly in design, but are essentially equivalent. First strand cDNA is synthesized from either total or poly(A) RNA in a reverse transcription reaction. A defined sequence is then added to the 3' end of the first strand cDNA by tailing with terminal deoxytransferase (TdT), or by ligation of an oligonucleotide adapter. Finally, a gene specific primer is used in conjunction with a primer for the added 3' sequence to amplify the sequence between the adapter and the gene specific primer at the 5' end of the cDNA. Traditional 5' RACE is sometimes successful, but the major limitation of the procedure is that there is no selection for amplification of fragments corresponding to the actual 5' ends of mRNA: all cDNAs are acceptable templates in the reaction. Additionally, the PCR step selects the most efficient amplicons (e.g., the smallest), favoring amplification of less than full-length products. 5' RACE usually produces a heterogeneous population of amplified products.

RLM-RACE

RNA Ligase Mediated Rapid Amplification of cDNA Ends (RLM-RACE) represents a major improvement to the classic RACE technique (Maruyama and Sugano, 1994, Shaefer, 1995). RLM-RACE is designed to amplify cDNA *only* from full-length, capped mRNA, usually producing a single band after PCR. The Ambion RLM-RACE Kit is optimized for efficiency and reliability. The procedure is shown schematically in Figure 1.

Figure 1. Overview of the RLM-RACE Procedure

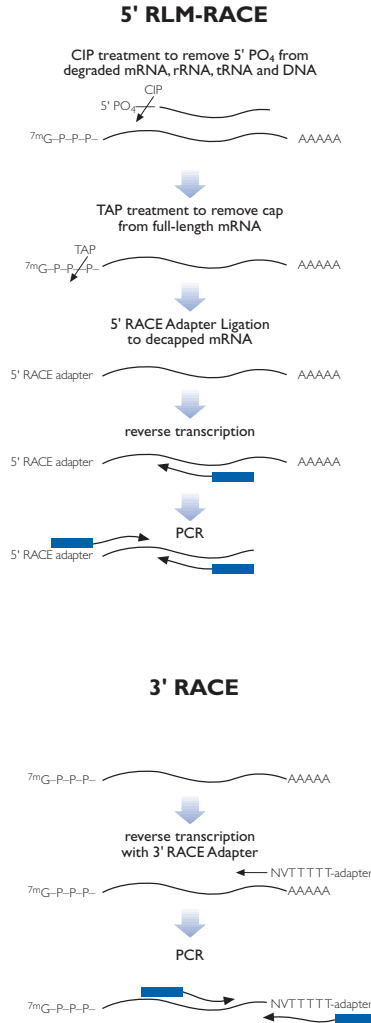

B. RLM-RACE Procedure Overview

5' RACE using the RLM-RACE Kit

Total or poly(A) selected RNA is treated with Calf Intestine Alkaline Phosphatase (CIP) to remove free 5'-phosphates from molecules such as ribosomal RNA, fragmented mRNA, tRNA, and contaminating genomic DNA. The cap structure found on intact 5' ends of mRNA is not affected by CIP. The RNA is then treated with Tobacco Acid Pyrophosphatase (TAP) to remove the cap structure from full-length

mRNA, leaving a 5'-monophosphate. A 45 base RNA Adapter oligonucleotide is ligated to the RNA population using T4 RNA ligase. The adapter cannot ligate to dephosphorylated RNA because these molecules lack the 5'-phosphate necessary for ligation. During the ligation reaction, the majority of the full length, decapped mRNA acquires the adapter sequence as its 5' end. A random-primed reverse transcription reaction and nested PCR then amplifies the 5' end of a specific transcript. Ambion provides two nested primers corresponding to the 5' RACE Adapter sequence, and the user supplies two nested antisense primers specific to the target gene. Guidelines for the design of gene-specific primers can be found in section [I.D](#) on page 8. We also provide RNA and PCR primers for mouse α -2-macroglobulin for use in control reactions.

3' RACE using the RLM-RACE Kit

The RLM-RACE Kit can also be used to amplify and clone sequence at the 3' end of an mRNA using the 3' RACE technique. 3' RACE is generally a much easier procedure than 5' RACE. First strand cDNA is synthesized from either total RNA or poly(A)-selected RNA, using the supplied 3' RACE Adapter (the sequence of which can be found in section [I.D](#), on page 4). The cDNA is then subjected to PCR using one of the 3' RACE Primers which are complimentary to the anchored adapter, and a user-supplied primer for the gene-of-interest. 3' RACE may not require a nested PCR, but a pair of nested primers for the Adapter sequence are provided in case nested PCR is determined to be necessary. We also provide a 3' RACE Control Primer for mouse β -actin as a control. It is not recommended to use the 3' RACE Adapter primer as first strand primer for 5' RACE as this would require the reverse transcriptase to transcribe through the entire mRNA to reach the 5' Adapter sequence.

RLM-RACE permits ligation of the synthetic RNA adapter only to decapped (full-length) RNA. Additionally, RLM-RACE selects for full length, first strand cDNA synthesis: any first strand cDNA molecules that do not extend all the way to the 5' end of the adapter will not yield product in the PCR (since these targets would lack the adapter-specific primer binding sites). Together, these features insure that only true 5' ends of transcripts are amplified.

C. Input RNA Requirements

It is not necessary to use poly(A) selected RNA as template in the RLM-RACE procedure. At Ambion, we have successfully amplified the 5' ends of rare targets starting with total cellular RNA. Using poly(A) RNA in RLM-RACE, however, may increase the likelihood of success for amplification of rare or difficult-to-amplify targets. It is essential that the starting RNA be of the best possible quality. Only full-length, capped message will be amplifiable in the RLM-RACE procedure.

D. Materials Provided with the Kit and Storage Conditions

Store the RLM-RACE Kit in a non frost-free freezer. Avoid contaminating any reagent with nuclease. Reagents for 6 CIP, TAP, ligation, and reverse transcription reactions – and primers for 100 nested PCR reactions are included.

Amount	Component	Storage
12 µL	Calf Intestine Alkaline Phosphatase	-20°C
50 µL	10X CIP Buffer	-20°C
12 µL	Tobacco Acid Pyrophosphatase	-20°C
50 µL	10X TAP Buffer	-20°C
12 µL	T4 RNA Ligase	-20°C
50 µL	10X T4 RNA Ligase Buffer	-20°C
10 µL	5' RACE Adapter (0.3 µg/µL) 5'-GCUGAUGGCGAUGAAUGAACACUGCGUUUGCUGGCUUUGAUGAAA-3'	-20°C
10 µL	3' RACE Adapter 5'-GCGAGCACAGAATTAATACGACTCACTATAGGT12VN-3'	-20°C
200 µL	5' RACE Outer Primer 10 µM 5'-GCTGATGGCGATGAATGAACACTG-3'	-20°C
200 µL	5' RACE Inner Primer 10 µM 5'-CGCGGATCCGAACACTGCGTTTGCTGGCTTTGATG-3'	-20°C
200 µL	3' RACE Outer Primer 10 µM 5'-GCGAGCACAGAATTAATACGACT-3'	-20°C
200 µL	3' RACE Inner Primer 10 µM 5'-CGCGGATCCGAATTAATACGACTCACTATAGG-3'	-20°C
1 mL	Ammonium Acetate Stop Solution	-20°C
10 µL	M-MLV Reverse Transcriptase	-20°C
500 µL	dNTP Mix (2.5 mM each dNTP)	-20°C
50 µL	10X RT Buffer	-20°C
1.25 mL	10X PCR Buffer	-20°C
12 µL	Random Decamers (50 µM)	-20°C
10 µL	RNase Inhibitor (10 U/µL)	-20°C
10 µL	Mouse Thymus RNA (1 mg/mL)	-20°C
25 µL	5' RACE Outer Control Primer 10 µM 5'-GATCACCAATCCATTGCCGACTAT-3'	-20°C
25 µL	5' RACE Inner Control Primer 10 µM 5'-GAAGTAGATGGTGGGCAGGAAGAT-3'	-20°C
25 µL	5' PCR Control Primer 10 µM 5'-GCAGCAGGTAGCAGTGAC-3'	-20°C
25 µL	3' RACE Control Primer 5'-AGCAGTTGGTTGGAGCAAACATC-3'	-20°C
1.75 mL	Nuclease-free Water	any temp*

* Store Nuclease-free Water at -20°C, 4°C or room temp.

E. Materials Not Provided with the Kit

RLM-RACE specific reagents:

- Gene-specific PCR primer(s). See section [II.C](#) starting on page [8](#) for details
- Acid phenol:chloroform – molecular biology grade
- Chloroform – molecular biology grade
- Thermostable DNA polymerase—recommended: Ambion SuperTaq™, recombinant thermostable DNA polymerase or SuperTaq™ Plus Extended Range Taq polymerase.
- Thermal cycler (e.g., Applied Biosystems GeneAmp® PCR System 9700 and the Veriti™ 96-Well Thermal Cycler)
- A method to clone PCR products: either a linearized cloning vector (see sections [II.F](#) on page 9 and [V.A](#) on page 18) or a ‘quick cloning system’ like the TA cloning kit from Invitrogen

General reagents:

- Disposable, RNase-free, pipette tips, polypropylene 1.5 mL microcentrifuge tubes and thin wall microfuge tubes for PCR
- Materials and equipment for gel electrophoresis
- Reagent grade isopropanol
- Reagent grade ethanol
- Cold 70% ethanol made with reagent grade ethanol

F. Related Products Available from Ambion

<p>*SuperTaq™ P/N AM2050, AM2052</p>	Thermostable DNA Polymerase (includes 10X buffers and dNTPs)
<p>†SuperTaq™ Plus P/N AM2054, (50U) P/N AM2056, (250U)</p>	<p>Extended Range Thermostable DNA Polymerase</p> <p>Super Taq Plus has a proof reading activity, and produces significantly higher yields of PCR products than ordinary Taq polymerase (includes 10X buffers and dNTPs)</p>
<p>Phenols See web or print catalog for P/Ns</p>	Ambion offers a full line of prepared phenol solutions for most molecular biology needs. These premixed, quality-tested, saturated phenols are ready-to-use and eliminate the handling concerns associated with preparing phenol for use from solid phenol.
<p>Electrophoresis Reagents See web or print catalog for P/Ns</p>	Ambion offers gel loading solutions, agaroses, acrylamide solutions, powdered gel buffer mixes, nuclease-free water, and RNA and DNA molecular weight markers for electrophoresis. Please see our catalog or our website (www.ambion.com) for a complete listing as this product line is always growing.

* Use of this product is covered by US patent claims and patent claims outside the US. The purchase of this product includes a limited, non-transferable immunity from suit under the foregoing patent claims for using only this amount of product for the purchaser's own internal research. No right under any other patent claim (such as the patented 5' Nuclease Process claims), no right to perform any patented method, and no right to perform commercial services of any kind, including without limitation reporting the results of purchaser's activities for a fee or other commercial consideration, is conveyed expressly, by implication, or by estoppel. This product is for research use only. Diagnostic uses under Roche patents require a separate license from Roche. Further information on purchasing licenses may be obtained by contacting the Director of Licensing, Applied Biosystems, 850 Lincoln Centre Drive, Foster City, California 94404, USA.

† Use of this product is covered by US patent claims and patent claims outside the US. The purchase of this product includes a limited, non-transferable immunity from suit under the foregoing patent claims for using only this amount of product for the purchaser's own internal research. No right under any other patent claim (such as the patented 5' Nuclease Process claims) and no right to perform commercial services of any kind, including without limitation reporting the results of purchaser's activities for a fee or other commercial consideration, is conveyed expressly, by implication, or by estoppel. This product is for research use only. Diagnostic uses require a separate license from Roche. Further information on purchasing licenses may be obtained by contacting the Director of Licensing, Applied Biosystems, 850 Lincoln Centre Drive, Foster City, California 94404, USA.

II. Input RNA and PCR Primer Design

A. RNA Quality

It is important to determine that the mRNA target is expressed in the RNA that is being considered for use in RLM-RACE. If there is any doubt, consider testing RNA samples from several tissue sources by Northern hybridization, ribonuclease protection assay, or RT-PCR to identify an RNA source that contains the highest proportion of the target RNA.

High quality total or poly(A) selected RNA should be used for RLM-RACE. Starting with poly(A) RNA will afford a 20–50 fold enrichment of the target, but it is usually not necessary for successful RLM-RACE. Ambion RiboPure™, MagMAX™, and RNAqueous® Kits all yield extremely clean RNA, suitable for RLM-RACE. RNA prepared with single step RNA isolation procedures, e.g., TRI Reagent® (Ambion P/N AM9738) can also be used. Regardless of the method used to purify the RNA, if there is any question about the cleanliness of the prep (e.g. low $A_{260}:A_{280}$ ratio), the RNA should be further purified with an organic extraction and alcohol precipitation. RNA can be assessed for integrity by running an aliquot on a bioanalyzer or on a denaturing agarose gel. Look for a 28S ribosomal RNA band that is twice the intensity of the 18S band. Also, both bands should be tight, with no smearing; these features are good indicators of very high quality RNA.

B. Critical Details in the Procedure

The CIP, TAP, and ligase reactions are robust and typically do not require user optimization. Exceeding the recommended RNA concentration in the CIP, TAP, or ligation reactions, however, may compromise the reaction(s). In particular, if poly(A) RNA is used as template, limit the amount of RNA in the TAP reaction to 250 ng as specified in the protocol.

A phenol/chloroform extraction and ethanol precipitation following the CIP treatment is included in the protocol because it is critical to remove all traces of CIP enzyme. Be certain to thoroughly homogenize the phenol:chloroform with the sample by vigorous vortexing at this step.

It is recommended that the minus-TAP control reaction be run, and that PCR annealing temperatures be optimized. The minus-TAP reaction can be used to assess whether the products produced by the procedure are true 5' RACE products. Although we have seen successful RACE for 5' targets with no optimization of cycling parameters, most targets require some tinkering with the PCR annealing temperature to generate discrete RACE products with minimal background. The RLM-RACE kit contains primers for 100 PCRs; this is more than enough to optimize most PCR protocols.

C. General PCR Primer Design Suggestions

Use the following PCR primer design recommendations:

- 20–24 bases in length
- 50% G:C content, with no secondary structure
- Avoid placing more than 3 G or C residues in the 3'-most 5 bases
- Avoid primers with a G as the 3'-terminal base
- Avoid sequences with 3' ends that can self-hybridize or hybridize to the 3' ends of the other primer in the PCR (forming primer dimers)
- Finally, using primer design software, evaluate your gene-specific primers in combination with the corresponding RACE Primer.

Figure 2 shows where the gene-specific primers should lie, and where the primers supplied with the kit are positioned.

Figure 2. Primer positions for 5' and 3' RACE

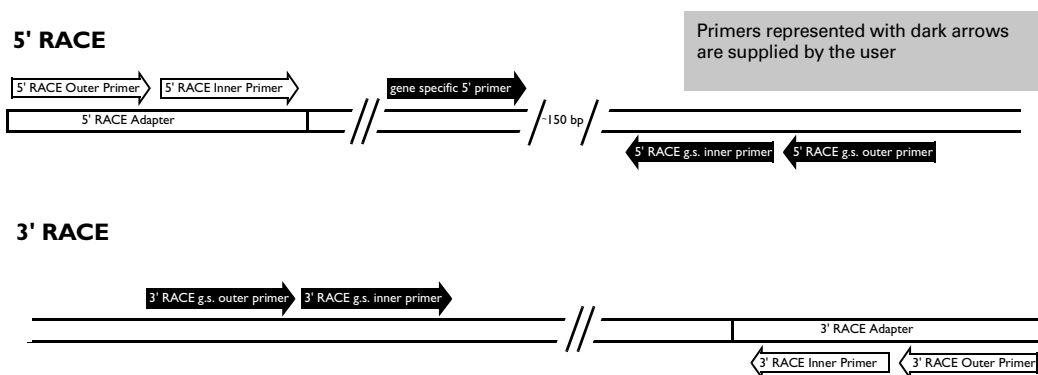

D. Primer Design for 5' RLM-RACE

1. Nested gene-specific downstream (3' or antisense) primers

The sequences of the 5' RACE Outer and Inner Primers are shown in the list of materials provided with the kit on page 4. The inner primers include a BamH1 site at the 5' end. The 5' RACE Primers work well in PCR using an annealing temperature of 55–65°C (they are typically used at ~60°C). Use primer design software to choose two nested sequences of similar length and melting temperature as PCR primers for your gene. If the distance to the 5' end of the RNA is known, your primers should be designed to anneal no closer than 150–200 bases downstream of the beginning of the RNA transcript to produce a large enough PCR product to evaluate by gel electrophoresis. If the distance to the 5' end of the RNA is unknown, position the gene-specific primers as far 5' as possible, leaving room to design an upstream primer as a positive control (i.e., ~150 bp downstream of the 5' end of the known sequence). 5' RACE gene-specific primers must be in the reverse com-

plement orientation to the coding sequence of the mRNA so that they prime the antisense strand in PCR. The spacing between the inner and outer nested primers is not critical, although placing them 50–100 base pairs apart will produce PCR fragments that can be easily distinguished by size. If the RACE products will be cloned using restriction sites, design the inner gene-specific primer with a restriction enzyme site at its 5' end (see section [II.F](#) on page 9).

2. Gene-specific 5' (upstream or sense) primer

To assist in the analysis and optimization of your reactions, we recommend synthesizing an upstream (sense-strand) gene specific primer positioned so that it produces a resolvable (≥ 150 bp) product in PCR when used with the 5' RACE gene-specific outer primer. Choose a sequence that is compatible in standard PCR with the corresponding gene-specific primers. This upstream primer can be used in conjunction with your gene specific 5' RACE primers to verify the presence of the target in an RNA preparation, and to evaluate RLM-RACE products (as described in section [VI.A.3](#) on page 22).

E. Primer Design for 3' RACE

The sequences of the 3' RACE Inner and Outer Primers are shown in the list of materials provided with the kit on page [4](#). Basic PCR primer design considerations as discussed above should be followed. If the distance from your primers to the 3' end of the target is larger than 1 kb or is unknown, Ambion recommends using an extended-range Taq polymerase to have the best chance of success. The 3' RACE protocol describes nested PCR, however 3' RACE reactions may produce significant product after a single round of PCR. You can try a PCR with a gene specific primer and the 3' RACE Outer Primer, if enough product is amplified, the inner nested reaction may be omitted.

F. Cloning RACE products

The 5' RACE Inner Primer and the 3' RACE Inner Primer have BamH1 sites at their 5' end (CGCGGATCC). If the inner gene specific primers also have restriction sites at their 5' end, PCR fragments generated in the “inner” PCR reactions can be ligated into a digested plasmid vector using standard cloning techniques. We recommend using a restriction site other than BamH1 on inner gene specific primers, so that fragments can be directionally cloned into a double-digested vector. Alternatively, one of the ‘quick PCR cloning’ kits which use Topoisomerase or T/A overhangs to facilitate cloning can be used to clone reaction products without restriction enzyme sites.

III. 5' RLM-RACE Protocol

A. RNA Processing

Standard reaction

This protocol is optimized for starting with 10 µg of total RNA, or 250 ng of poly(A)-selected RNA. Using these amounts of RNA will be referred to as the “*standard*” reaction. This provides extra material in case of partial sample loss or if a downstream reaction must be repeated.

Small-scale reaction

If only an extremely limited amount of RNA is available, the reaction can be scaled down to start with 1 µg or less total RNA. Modifications to the protocol for the use of only 1 µg of total RNA as template are referred to as “*small*” reactions.

1. Treat with CIP at 37°C for 1 hr

- a. Assemble the following components in an RNase-free microcentrifuge tube:

Amount	Component
X µL	<i>standard rxn</i> : 10 µg total or 250 ng poly(A) RNA <i>small rxn</i> : 1 µg total RNA
2 µL	10X CIP buffer
2 µL	Calf Intestine Alkaline Phosphatase (CIP)
to 20 µL	Nuclease-free Water

- b. Mix gently, spin briefly. Incubate at 37°C for one hour.

2. Terminate CIP reaction and extract with phenol:chloroform, then with chloroform

- a. Add:

Amount	Component
15 µL	Ammonium Acetate Solution
115 µL	Nuclease-free Water
150 µL	acid phenol:chloroform*

* Empirically, we have seen slightly better results with acid phenol:chloroform than with ordinary phenol:chloroform.

- b. Vortex thoroughly. Centrifuge 5 mins., room temperature at top speed in a microfuge (≥10,000 x g). Transfer aqueous phase (top layer) to a new tube.
- c. Add 150 µL chloroform, vortex thoroughly, centrifuge 5 mins., room temperature at top speed in a microfuge (≥10,000 x g). Transfer aqueous phase (top layer) to a new tube.

3. Precipitate with 150 μ L isopropanol on ice for 10 min, then pellet RNA and rinse with cold 70% ethanol

- Add 150 μ L isopropanol, vortex thoroughly. Chill on ice for 10 minutes.
- Centrifuge at maximum speed for 20 minutes. Rinse pellet with 0.5 mL cold 70% ethanol, centrifuge 5 minutes at maximum speed, remove ethanol carefully and discard it. Allow pellet to air dry.

4. Resuspend RNA in Nuclease-free Water

Standard reaction: Resuspend pellet in 11 μ L Nuclease-free Water. (Optional: reserve 1 μ L of CIP-treated RNA at -20°C for a 'minus-TAP' control reaction – see section [V.L.B.2](#) on page 24.)

Small reaction: Prepare 10 μ L of 1X TAP Buffer, and resuspend sample in 4 μ L of it.

Place the majority of the sample on ice and proceed to TAP reaction, or store the sample at -20°C .

5. Treat with TAP at 37°C for 1 hr

- Assemble the components in an RNase-free microcentrifuge tube:

standard rxn	small rxn	Component
5 μ L	4 μ L	CIP'd RNA (from above)
1 μ L	--	10X TAP buffer
2 μ L	1 μ L	Tobacco Acid Pyrophosphatase
2 μ L	--	Nuclease-free Water

- Mix gently, spin briefly. Incubate at 37°C for one hour.
- Store reaction at -20°C or proceed to ligation step.

6. 5' RACE Adapter Ligation

- Assemble the components in an RNase-free microfuge tube:

standard rxn	small rxn	Component
2 μ L	5 μ L	CIP/TAP-treated RNA
1 μ L	1 μ L	5' RACE Adapter
1 μ L	1 μ L	10X RNA Ligase Buffer*
2 μ L	2 μ L	T4 RNA Ligase (2.5 U/ μ L)
4 μ L	1 μ L	Nuclease-free Water

* Before use, warm the 10X RNA Ligase Buffer quickly by rolling it between gloved hands to resuspend any precipitate. Since this buffer contains ATP, it is not recommended to heat it over 37°C , as this would compromise the ATP.

- Mix gently, spin briefly.
- Incubate at 37°C for one hour.
- Store reaction at -20°C or proceed to the reverse transcription.

B. Reverse Transcription

1. Assemble reverse transcription reaction

- a. Assemble the following in an RNase-free microfuge tube on ice:

Amount	Component
2 µL	Ligated RNA (or minus-TAP control)
4 µL	dNTP Mix
2 µL	Random Decamers
2 µL	10X RT Buffer
1 µL	RNase Inhibitor
1 µL	M-MLV Reverse Transcriptase
to 20 µL	Nuclease-free Water

- b. Mix gently, spin briefly.

2. Incubate at 42°C for 1 hr

- a. Incubate at 42°C for one hour.
b. Store reaction at –20°C or proceed to the PCR step.

C. Nested PCR for 5' RLM-RACE

Minus-template control

It is always a good idea to include a minus-template control in any PCR. This control should include all of the PCR components used in the experimental samples except template. If anything amplifies in this reaction, it indicates that one or more of the PCR reagents is contaminated with DNA.

1. Outer 5' RLM-RACE PCR

- a. Assemble the components in PCR tubes on ice:



IMPORTANT

Ambion recommends a hot start for PCRs. At a minimum, assemble reactions on ice, preheat thermal cycler to 94°C, and then place the tubes in the thermal cycler.

Amount	Component
1 µL	RT reaction (from the previous step)
5 µL	10X PCR Buffer*
4 µL	dNTP Mix
2 µL	5' RACE gene-specific outer primer (10 µM)
2 µL	5' RACE Outer Primer
to 50 µL	Nuclease-free Water
1.25 U	thermostable DNA polymerase† (0.25 µL of 5U/µL)

* Use the 10X PCR Buffer supplied with your thermostable DNA polymerase, or use the one supplied with the RLM-RACE Kit.

† We strongly recommend using an extended range thermostable DNA polymerase, such as SuperTaq-Plus, for targets over 1 kb.

**NOTE**

Thermal cyclers with very short ramp times, may require slightly longer incubation times, whereas machines with virtually no ramp time, such as Stratagene's RoboCycler®, will probably require 1 minute at each temperature in the cycle.

- b. Mix gently, flick tube or spin briefly to return the contents to the bottom of the tube.
- c. Cycle as follows:

	Stage	Reps	Temp	Time
Initial denaturation	1	1	94°C	3 min
Amplification	2	35	94°C	30 sec
			60°C*	30 sec
			72°C	30 sec
Final extension	3	1	72°C	7 min

* The 5' RACE Outer Primer works well in PCR using an annealing temperature from 55 to 65°C. Therefore, an annealing temperature of 60°C is probably a reasonable starting point. The optimal temperature for your primer and template combination may have to be determined empirically.

For targets longer than 1 kb, add 1 minute to the 72°C extension time for each kilobase. For example, the 35 cycles for a 3 kb target would be: 94°C – 30 sec, 60°C – 30 sec, 72°C – 3 minutes

2. Inner 5' RLM-RACE PCR

- a. Assemble the components in PCR tubes on ice:

Amount	Component
1–2 µL	Outer PCR (from the previous step – III.C.1)
5 µL	10X PCR Buffer
4 µL	dNTP Mix
2 µL	5' RACE gene specific inner primer (10 µM)
2 µL	5' RACE Inner Primer
to 50 µL	Nuclease-free Water
1.25 U	thermostable DNA polymerase (0.25 µL of 5U/µL)

- b. Mix gently, flick tube or spin briefly to return the contents to the bottom of the tube.
- c. Use the same PCR cycling profile as in the outer 5' RLM-RACE PCR.

D. Gel Analysis of Products and Expected Results

After the PCR is complete, run 5–10 µL of each sample in a 2% high resolution agarose gel containing 1 µg/mL ethidium bromide and visualize on a UV transilluminator. A sample of the outer PCR can also be run for evaluation since a product is sometimes visible after the primary PCR. There should be one to a few bands from the nested PCR from the experimental samples, and the minus-template control sample

should have no visible PCR product. In the event no bands are present in the experimental samples, or if there is an unexpectedly complicated pattern (e.g. a smear), optimization of the procedure, as described in section [VLB](#) on page 23 may be beneficial.

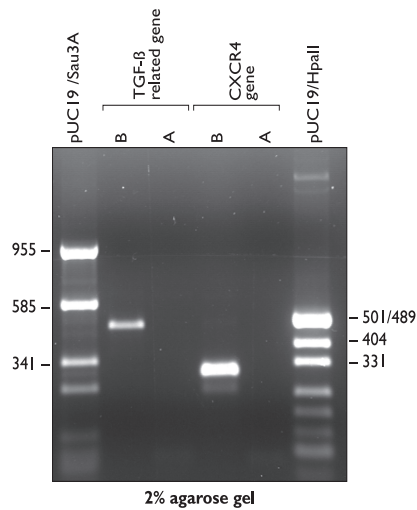

Figure 3. RLM-RACE for Mouse CXCR-4 Gene and *Xenopus* TGF-β Related Gene

Mouse liver RNA and *Xenopus* stage 41 embryo RNA were used in the RLM-RACE kit. A: Outer 5' RACE PCR. B: Inner 5' RACE PCR. CXCR-4 is a moderately-expressed message, and the TGF-β related gene encodes a very rare message.

IV. 3' RLM-RACE Protocol

A. Reverse Transcription

- a. Assemble the following in an RNase-free microfuge tube on ice:

Amount	Component
2 μ L	RNA – use 1 μ g total RNA or 50 ng poly(A) RNA
4 μ L	dNTP Mix
2 μ L	3' RACE Adapter
2 μ L	10X RT Buffer
1 μ L	RNase Inhibitor
1 μ L	M-MLV Reverse Transcriptase
8 μ L	Nuclease-free Water

- b. Mix gently, spin briefly.
 c. Incubate at 42°C for one hour.
 d. Store reaction at –20°C or proceed to the PCR step.

B. PCR for 3' RLM-RACE

Often, a single PCR will amplify enough product from 3' RACE. In case a second PCR is necessary to provide more material or greater specificity, two nested primers for the 3' RACE Adapter sequence are provided with this kit. Do an outer PCR first, and then do the inner PCR only if necessary.

Minus-template control

It is always a good idea to include a minus-template control in any PCR. This control should include all of the PCR components used in the experimental samples except template. If anything amplifies in this reaction, it indicates that one or more of the PCR reagents is contaminated with DNA.

1. Outer 3' RLM-RACE PCR

a. Assemble the components in PCR tubes on ice:



IMPORTANT

Ambion recommends a hot start for PCR reactions. At a minimum, assemble reactions on ice, preheat thermal cycler to 94°C, and then place the tubes in the thermal cycler.

Amount	Component
1 µL	RT reaction (from the previous step)
5 µL	10X PCR Buffer*
4 µL	dNTP Mix
2 µL	3' RACE gene-specific outer primer (10 µM)
2 µL	3' RACE Outer Primer
to 50 µL	Nuclease-free Water
1.25 U	thermostable DNA polymerase† (0.25 µL of 5U/µL)

* Use the 10X PCR Buffer supplied with your thermostable DNA polymerase, or use the one supplied with the RLM-RACE Kit.

† We strongly recommend using an extended range thermostable DNA polymerase, such as SuperTaq-Plus, for targets over 1 kb.

b. Mix gently, flick tube or spin briefly to return the contents to the bottom of the tube.



NOTE

Thermal cyclers with very short ramp times, may require slightly longer incubation times, whereas machines with virtually no ramp time, such as Stratagene's RoboCycler®, will probably require 1 minute at each temperature in the cycle.

c. Cycle as follows:

	Stage	Reps	Temp	Time
Initial denaturation	1	1	94°C	3 min
Amplification	2	35	94°C	30 sec
			60°C*	30 sec
			72°C	30 sec
Final extension	3	1	72°C	7 min

* The 3' RACE Outer Primer works well in PCR using an annealing temperature from 55 to 65°C. Therefore, an annealing temperature of 60°C is probably a reasonable starting point. The optimal temperature for your primer and template combination may have to be determined empirically.

For targets longer than 1 kb, add 1 min to the 72°C extension time for each kilobase. For example, the 35 cycles for a 3 kb target would be: 94°C – 30 sec, 60°C – 30 sec, 72°C – 3 minutes

2. Inner 3' RLM-RACE PCR (optional)

Do this PCR if the outer PCR yield is low, or if the outer PCR yields a smear of products instead of a discrete band(s).

- a. Assemble the components in PCR tubes on ice:

Amount	Component
1 μ L	Outer 3' RACE PCR (from previous step – IV.B.1)
5 μ L	10X PCR Buffer
4 μ L	dNTP Mix
2 μ L	3' RACE gene-specific inner primer (10 μ M)
2 μ L	3' RACE Inner Primer
to 50 μ L	Nuclease-free Water
1.25 U	thermostable DNA polymerase (0.25 μ L of 5U/ μ L)

- b. Mix gently, flick tube or spin briefly to return the contents to the bottom of the tube.
- c. Use the same PCR cycling profile as in the outer 3' RLM-RACE PCR.

C. Gel Analysis of Products and Expected Results

Run 5–10 μ L of each PCR in a 2% agarose gel containing 1 μ g/mL EtBr and visualize on a UV transilluminator. If you have done both the inner and outer PCRs, run samples from both reactions to compare the products. There should be one to a few bands from the PCR. If no bands are present, or if there is an unexpectedly complicated pattern (e.g. a smear), optimization of the procedure, as described in section [VI.B](#) on page 23 may help.

V. Cloning and Sequence Analysis of Products

A. Cloning

RACE products can be cloned into suitable plasmid vectors using standard techniques. Both the 5' RACE Inner Primers and 3' RACE Inner Primers have BamH1 sites at their 5' ends. So, RACE products amplified with a gene-specific primer that also has a restriction site can be cloned into an appropriately digested plasmid vector using standard cloning techniques (see Current Protocols in Molecular Biology). Alternatively, one of the 'quick PCR cloning' kits can be used to clone RACE products without using restriction enzymes. Before sequencing a clone, do a diagnostic restriction digest to confirm the presence of the expected size insert.

If the nested PCR produced several bands, this may indicate alternative transcriptional start sites, polyadenylation sites, or splicing products. Alternatively, it may be an indication that the PCRs should be thermal cycled at higher stringency. The pattern of bands may be greatly simplified by raising the annealing temperature to 60°C or higher. If you want to analyze all the products, they can be cloned en masse and sorted out by restriction digest of individual bacterial colonies, or each band can be gel-purified, and cloned individually.

B. Sequence Analysis

As with any cloning experiment, it is a good idea to check insert size by restriction digest before going to the expense and trouble of sequencing.

5' RLM-RACE

5' RLM-RACE products should contain a clean splice at the junction of the 5' RACE Adapter and the mRNA. When analyzing the sequence of 5' RLM-RACE products, it is advisable to sequence more than one clone.

The 5' RACE Adapter will add 45 bp to your experimental outer PCR product, and 36 bp to your experimental inner PCR product. The sequence that will be added to your product after the inner PCR (using the 5' RACE Inner Primer and your gene-specific primer) is the following (assuming that no spurious rearrangement or cloning artifact has occurred):

CGCGGATCCGAACACTGCGTTTGCTGGCTTTGATGAAA–your sequence
(bold sequence is the BamH1 site)

3' RLM-RACE

3' RACE products should contain either the 3' RACE Outer Primer or the 3' RACE Inner Primer sequence at the junction of the 3' RACE Adapter and the mRNA, depending on which was used in the final PCR (assuming that no spurious rearrangement or cloning artifact has occurred).

- 3' RACE Outer Primer used in final PCR:
5'-**GCGAGCACAGAATTAATACGACT**CACTATAGGT₁₂VN-your sequence
(bold sequence represents the 3' RACE Outer Primer sequence.)
- 3' RACE Inner Primer used in final PCR:
5'-CGC**GGATCC**GAATTAATACGACTCACTATAGGT₁₂VN-your sequence
(bold sequence is the BamHI site)

When analyzing the sequence of RACE products, it is advisable to sequence more than one clone.

VI. Troubleshooting

A. Using the Positive Controls

An aliquot of Mouse Thymus RNA and a set of control primers is included with the RLM-RACE kit to test both 5' and 3' RACE, and PCR.

1. 5' RACE control

a. Purpose of the control

Nested primers for CXCR-4 are provided to verify that the RLM-RACE components are functioning properly. CXCR-4 is a G-protein-coupled chemokine receptor (Ganju, et al. 1998). It is over-expressed in glioblastoma and other brain tumors (Sehgal et al 1998). CXCR-4 is also a co-receptor for T-tropic human immunodeficiency virus type 1 (HIV-1) (Parolin, et al. 1998).

Figure 4. 5' RACE Control

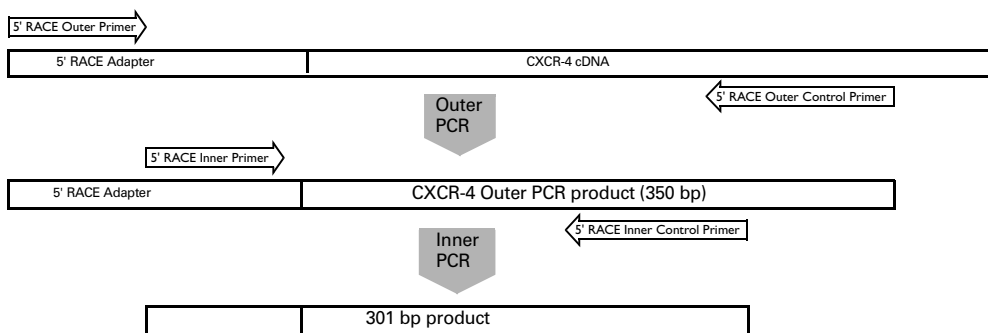

b. RNA processing and reverse transcription

Use 10 µg of the Mouse Thymus RNA in RLM-RACE following the instructions in section [III.A](#) on page 10 through [III.B](#) on page 12.

c. Nested PCR for 5' RACE

For the PCRs, amplify 1 µL of the RT reaction from the previous step using the 5' RACE Outer Primer with the 5' RACE Outer Control Primer in PCR using an annealing temperature of 60°C (instructions in section [III.C.1](#) on page 12). This produces a 350 bp product that is typically too faint to see when run on an ethidium bromide-stained agarose gel.

Use 1 µL of the outer PCR as template in the nested PCR with the 5' RACE Inner Primer with the 5' RACE Inner Control Primer. The annealing temperature should be 60°C (instructions in section [III.C.2](#) on page 13).

d. Analysis and expected result

Analyze the results by running 5–10 μL of each sample in a 2% high resolution agarose gel containing 1 $\mu\text{g}/\text{mL}$ EtBr and visualizing on a UV transilluminator. The inner 5' RACE control PCR should generate a 301 bp PCR product. The Control primers are positioned at position 305 (Outer Primer) and 263 (Inner Primer) in Genbank accession #D87747 (CXCR-4).

If the 301 bp product is not generated in this reaction, identify whether there is a problem with the RT-PCR or with the RNA processing steps by doing the RT-PCR control described in section [VI.A.3](#) on page 22. Note that a second band is sometimes seen if the PCR has a very high yield. The extra band can usually be eliminated by either reducing the PCR template amount to only 10–50% the amount used initially, or by increasing the annealing temperature in the PCR by 2–3°C.

2. 3' RACE control

a. Purpose of the control

An upstream 3' RACE Control Primer for mouse β -actin is included in with the RLM RACE kit to perform 3' RACE on the Mouse Thymus RNA (or other mouse RNA if desired) to confirm functioning of the kit. This primer will be used in conjunction with the 3' RACE Outer Primer to amplify the 3' end of the β -actin gene. The 3' RACE Control Primer is at position 1424 in Genbank accession #MMACTBR.

Figure 5. 3' RACE Control

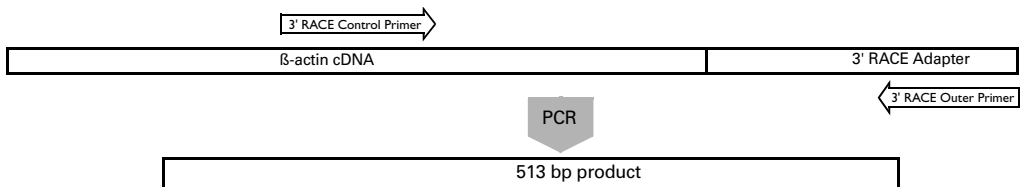

b. Reverse transcription

Use 1 μg of the Mouse Thymus RNA; follow the instructions in section [IV.A](#) on page 15.

c. 3' RACE PCR

Use 1 μL of the RT from the previous step in PCR with the 3' RACE Control Primer and the 3' RACE Outer Primer. Follow the setup and cycling instructions in section [IV.B](#) on page 15; the annealing temperature should be 60°C.

d. Analysis and expected result

Analyze the results by running 10 μL of each sample in a 2% high resolution agarose gel containing 1 $\mu\text{g}/\text{mL}$ EtBr and visualizing on a UV transilluminator. There should be a predominant 513 bp product from the PCR. We observe additional bands if the PCR yielded

a large amount of product; this can usually be eliminated by using only 10–50% as much starting cDNA, or by raising the annealing temperature by a few degrees. If no bands are present, this indicates a problem with the kit or with your PCR protocol.

3. RT-PCR control

a. Purpose of the control

An upstream ‘sense strand’ primer for CXCR-4 is provided so that the RT and PCR reactions can be evaluated independently of the CIP, TAP, and ligation reactions. (The tube label reads: 5' PCR Control Primer.) Do the control reactions described below if the 5' RACE control reaction gave unexpected results, or to check that the RT-PCR end of RLM-RACE is working properly.

Figure 6. RT-PCR Control

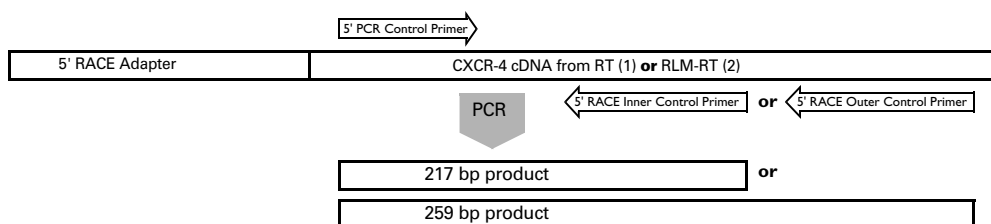

b. Set-up and cycling

The most complete control experiment would include two sets of RT-PCRs, with different input cDNA as described below:

- Template #1: An RT reaction should be performed on a 1 µg (2 µL) aliquot of the Mouse Thymus RNA provided in the kit. Follow the instructions in section III.B on page 12. The resulting cDNA (1 µL) should be used as template in control PCRs.
- Template #2: A 1 µL aliquot of the cDNA made from the 5' RACE control (in step VI.A.1.b. above) can be used directly in PCR.

Do two PCRs on each PCR template, (for a total of 4 reactions).

- One reaction should use the 5' PCR Control Primer with the 5' RACE Outer Control Primer,
- The other reaction should use the 5' PCR Control Primer with the 5' RACE Inner Control Primer.

Use an annealing temperature of 60°C and the cycling conditions described in section III.C on page 12.

c. Analysis and expected result

Analyze the results by running 10 µL of each sample in a 2% high resolution agarose gel containing 1 µg/mL EtBr and visualizing on a UV transilluminator. The expected fragment from the outer PCR is 259 bp, from the inner PCR, it is 217 bp. There should be a single

band from the PCR (sometimes we observe a second band if the amplification yielded a large amount of product or the annealing temperature was a little low).

Each of the reactions using template #1 should produce the expected size fragment. If the predicted fragment is not seen, there is a problem with the template, the PCR components, the experimental technique, or the thermal cycler. It is unlikely that RLM-RACE will be successful if these PCRs do not work.

If you see specific products using template #1, but not with template #2, your RLM-RACE RNA may be degraded. Repeat the PCR, doing more cycles. If the reactions still fail to produce the expected products, call Ambion's Technical Service Department for more help.

B. Optimization of RLM-RACE

As part of the development of this kit, the importance of each variable in every step of the RLM-RACE protocol were evaluated. The variable that had the most significant impact on the outcome of our experiments was optimization of PCR annealing temperatures. Using SuperTaq-Plus or another extended range Taq polymerase (in lieu of SuperTaq) for the PCRs, and raising the temperature of the reverse transcription reaction by using a thermal-tolerant reverse transcriptase sometimes greatly improved yield and specificity.

1. Possible causes of ambiguous results

Without optimization, nested PCR may produce no band, a single band, several bands, or a complicated pattern of bands (a smear). Smearing or failure to amplify could alternatively be caused by poor quality RNA, or absence of the target in the RNA used for RLM-RACE. The following discussion assumes that only very pure, high quality RNA known to contain the highest amount of target was used as starting material.

A complicated pattern of discrete bands may be due to multiple initiation sites for transcription of the target gene, or primer homology to several members of a multi-gene family. In some cases, primers can be designed to hybridize only with specific targets, but this is not possible without extensive sequence information.

Since it may not be possible to rule out all of the possible causes of confusing results such as no bands, several bands, or a smear of bands, we recommend trying to optimize the experiment using the suggestions in the following sections.

2. Minus-TAP control

An optional control consists of carrying a ‘minus-TAP’-treated sample (1 µL aliquot removed at step III.A.4.) through adapter ligation, reverse transcription and PCR. This will demonstrate that the products generated by RLM-RACE are specific to the 5' ends of *decapped* RNA.

At the end of the RLM-RACE procedure, the minus-TAP control RNA should *not* yield the same PCR products as the experimental RNA that underwent the entire RLM-RACE procedure. In theory, no bands should be produced since the RNA has either been dephosphorylated with CIP, or it has an intact cap structure (because it was not treated with TAP) that cannot undergo ligation to the 5' RACE Adapter. *Sometimes a smear of non-specific products is seen from the minus-TAP control RNA, this is not a concern.*

3. Test the gene-specific PCR primers

A useful control reaction is to test the inner and outer gene specific 5' RLM RACE primers by using each one of them in a PCR with a gene specific 5' primer and an aliquot of the RLM-RACE reverse transcription reaction as template (as described in section [VI.A.3. RT-PCR control](#) on page 22). Each reaction should produce a single band of the appropriate size. Failure to produce the appropriate bands in these control reactions is a strong indication that the cycling conditions are inappropriate, or that the gene specific primers should be redesigned. Sometimes reducing the concentration of the primers in the PCR by 50% reduces background significantly.

If the expected bands are produced in these control PCRs, optimize the RACE PCR by varying the annealing temperature as described below. Sometimes a complicated pattern (or no pattern at all) will resolve into a single band with an increase in stringency of the PCR.

4. Optimization of PCR annealing temperature

More than any other variable, optimization of the PCR annealing temperature will provide the greatest improvement to the outcome of the RLM-RACE protocol. There is ample experimental material for thorough optimization. Each reverse transcription reaction can provide template for 20 PCRs and 5' RACE Inner and Outer Primers for 100 PCRs are included in the kit. If you need more 5' RACE Inner and Outer Primers, their sequence is provided in section [L](#) on page 4. In general, the annealing temperature in the outer PCR is less critical, and should be 55–65°C. The annealing temperature of the inner, nested PCR may need to be higher than predicted by calculation or by primer design software to achieve the required selectivity in the amplification. If the PCR fails to give the expected results, repeat the experiment using a higher (try 2°C) annealing temperature.

5. Protocol modifications for long targets

Lack of a specific RLM-RACE product may be dependent on the distance between your nested primers and the 5' end of the target. The 72°C extension step of the amplification cycle should be extended

1 minute for each kilobase of target over 1 kb. Larger RACE products are more difficult to amplify in general. SuperTaq™ Plus (Ambion P/N AM2054 & AM2056, or similar products from other companies) has a proofreading activity, providing greater fidelity and processivity than ordinary thermostable DNA polymerase. In routine use, PCRs using extended range polymerases have higher yields, especially when the target amplicon is larger than 1 kb. The only drawback to using a 'long-Taq' instead of ordinary thermostable DNA polymerase is that PCR products might not be clonable using the T/A method. Otherwise, the robustness of most reactions will be improved by this simple substitution.



NOTE

SuperTaq Plus™ (P/N AM2054, AM2056) is compatible with T/A cloning.

6. Optimization of RNA denaturation prior to reverse transcription

GC-rich regions or other regions of stable secondary structure in RNA transcripts may present a problem for M-MLV Reverse Transcriptase at 42°C. By increasing the temperature of the reverse transcriptase reaction, secondary structure effects can be minimized. The M-MLV Reverse Transcriptase included in the RLM-RACE kit can be used at up to 50°C. Increasing the temperature of the synthesis reaction may facilitate read-through by the RT enzyme.

In extreme cases, a thermostable enzyme can be used for first strand synthesis. In one unusual experiment, the correct RACE product from a very GC-rich sequence was only obtained with the use of a thermostable reverse transcriptase. Such enzymes can be purchased from several commercial sources. If you choose to buy a thermostable reverse transcriptase, confirm that the manufacturer certifies that the enzyme is nuclease-free. Follow the recommended reaction conditions for the enzyme (e.g. use the supplier's RT reaction buffer—Ambion dNTPs can be used). Substitution of a thermostable enzyme should be considered only if optimization using the supplied kit components fails to yield the desired products.

VII. Appendix

A. References

- Ganju RK, Brubaker SA, Meyer J, Dutt P, Yang Y, Qin S, Newman W, Groopman JE. (1998) The alpha-chemokine, stromal cell-derived factor-1alpha, binds to the transmembrane G-protein-coupled CXCR-4 receptor and activates multiple signal transduction pathways. *J Biol Chem* **273**(36):23169-75
- Maruyama K and Sugano S. (1994) Oligo-capping: a simple method to replace the cap structure of eukaryotic mRNAs with oligoribonucleotides. *Gene* **138**:171-174
- Parolin C, Borsetti A, Choe H, Farzan M, Kolchinsky P, Heesen M, Ma Q, Gerard C, Palu G, Dorf ME, Springer T, Sodroski J. (1998) Use of murine CXCR-4 as a second receptor by some T-cell-tropic human immunodeficiency viruses. *J Virol.* **72**(2):1652-6.
- Sehgal A, Keener C, Boynton AL, Warrick J, Murphy GP. (1998) CXCR-4, a chemokine receptor, is overexpressed in and required for proliferation of glioblastoma tumor cells. *J Surg Oncol.* **69**(2):99-104.
- Shaefer, B. (1995) Revolution in rapid amplification of cDNA ends: new strategies for polymerase chain reaction cloning of full-length cDNA ends. *Analytical Biochem.* **227**:255-273.

B. Quality Control

Functional testing

All components are functionally tested in RLM-RACE following this protocol. PCR products are assessed on a 2% agarose gel.

Nuclease testing

Relevant kit components are tested in the following nuclease assays:

RNase activity

Meets or exceeds specification when a sample is incubated with 25 ng labeled RNA and analyzed by PAGE.

Nonspecific endonuclease activity

Meets or exceeds specification when a sample is incubated with 300 ng supercoiled plasmid DNA and analyzed by agarose gel electrophoresis.

Exonuclease activity

Meets or exceeds specification when a sample is incubated with 40 ng labeled *Sau3A* fragments of pUC19 and analyzed by PAGE.

Protease testing

Meets or exceeds specification when a sample is incubated with 1 µg protease substrate and analyzed by fluorescence.

C. Safety Information

The MSDS for any chemical supplied by Applied Biosystems or Ambion is available to you free 24 hours a day.



IMPORTANT

For the MSDSs of chemicals not distributed by Applied Biosystems or Ambion, contact the chemical manufacturer.

To obtain Material Safety Data Sheets

- Material Safety Data Sheets (MSDSs) can be printed or downloaded from product-specific links on our website at the following address: www.ambion.com/techlib/msds
- Alternatively, e-mail your request to: MSDS_Inquiry_CCRM@appliedbiosystems.com. Specify the catalog or part number(s) of the product(s), and we will e-mail the associated MSDSs unless you specify a preference for fax delivery.
- For customers without access to the internet or fax, our technical service department can fulfill MSDS requests placed by telephone or postal mail. (Requests for postal delivery require 1–2 weeks for processing.)

Chemical safety guidelines

To minimize the hazards of chemicals:

- Read and understand the Material Safety Data Sheets (MSDS) provided by the chemical manufacturer before you store, handle, or work with any chemicals or hazardous materials.
- Minimize contact with chemicals. Wear appropriate personal protective equipment when handling chemicals (for example, safety glasses, gloves, or protective clothing). For additional safety guidelines, consult the MSDS.
- Minimize the inhalation of chemicals. Do not leave chemical containers open. Use only with adequate ventilation (for example, fume hood). For additional safety guidelines, consult the MSDS.
- Check regularly for chemical leaks or spills. If a leak or spill occurs, follow the manufacturer's cleanup procedures as recommended on the MSDS.
- Comply with all local, state/provincial, or national laws and regulations related to chemical storage, handling, and disposal.



